

MODEL WVV TRANSDUCER AMPLIFIER

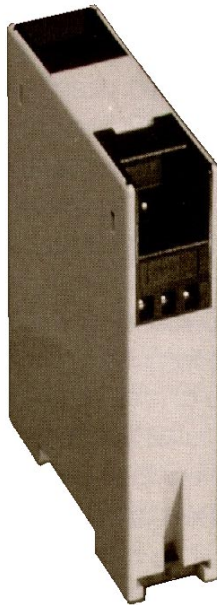

SENSOTEC

WeldSensor Group

2080 Arlingate Lane, Columbus, Ohio 43228 • (614)850-1140

Sensotec, Inc.

WeldSensor Group

2080 Arlingate Lane

Columbus, Ohio 43228 USA

Copyright © 2000 by Sensotec, Inc. all rights reserved

Telephone: (614)850-1140

FAX: (614)850-1141

Toll Free: 1-800-848-6564

E-mail: sales@sensotec.com

WWW: <http://www.weldsensor.com>

Model WVW Transducer Amplifier

(Bipolar Model, 10 volt output)

Sensotec Part Number: 008-0619-00

Rev. 0: May, 2001

IMPORTANT! IT IS RECOMMENDED THAT YOU READ THIS DOCUMENT THOROUGHLY BEFORE APPLYING POWER TO THIS UNIT. THIS DOCUMENT CONTAINS INFORMATION ON WIRING, CALIBRATION, AND USE OF FEATURES.

Chapter 1

INTRODUCTION

1.1 Overview.....	1-1
1.2 Specifications.....	1-2
1.3 Layout.....	1-3

Chapter 2

INSTALLATION / SETUP

2.1 Mounting.....	2-1
2.2 Wiring.....	2-1
2.2.1 General.....	2-1
2.2.2 Model WT or WIS Weld Current Sensors.....	2-1
2.3 Setup.....	2-3

Chapter 3

CALIBRATION

3.1 Calibration.....	3-1
3.2 Using Shunt Calibration.....	3-1

Chapter 4

WARRANTY / REPAIR POLICY

4.1 Limited Warranty on Products.....	4-1
4.2 Service Under Warranty.....	4-1
4.3 Non-Warranty Service.....	4-2
4.4 Repair Warranty.....	4-2

Chapter 1

INTRODUCTION

1.1 Overview

The Sensotec Model WV Transducer Amplifier features 35mm DIN-rail mounting and connects between the transducer and a readout instrument. The Model WV amplifier supplies a highly regulated bridge excitation voltage for the transducer and converts the millivolt signal of the transducer to a +/- 10 volts DC signal. The Model WV features two selectable excitation voltages, programmable gain settings for inputs of ± 1 VDC to ± 5 VDC, a wide adjustment range on the zero and a buffered solid-state shunt cal relay for quick calibration.

1.2 Specifications

Power Requirements:	15 - 28 volts DC
Bridge Excitation:	9 or 5.4 volts DC @ 30 mA (user selectable)
Output Voltage Range:	+/- 10 volts @ 2.5 mA
Frequency Response:	DC - 5000 Hz
Zero Balance Range:	+/- 30% coarse, +/- 5% fine adjustment range
Gain Adjustment Range:	Switch selectable (± 1 VDC to ± 5 VDC), +8%, -20% fine adjust
Short Circuit Protection:	(+)Output to (-)Output
Enclosure Style:	35mm DIN rail mounting
Enclosure Size:	22.5mm x 75mm x 98.5mm (0.886" x 2.953" x 3.878")
Shunt Calibration:	Solid-state relay
Long Term Zero Drift:	.1% of Full Scale per 6 months

1.3 Layout

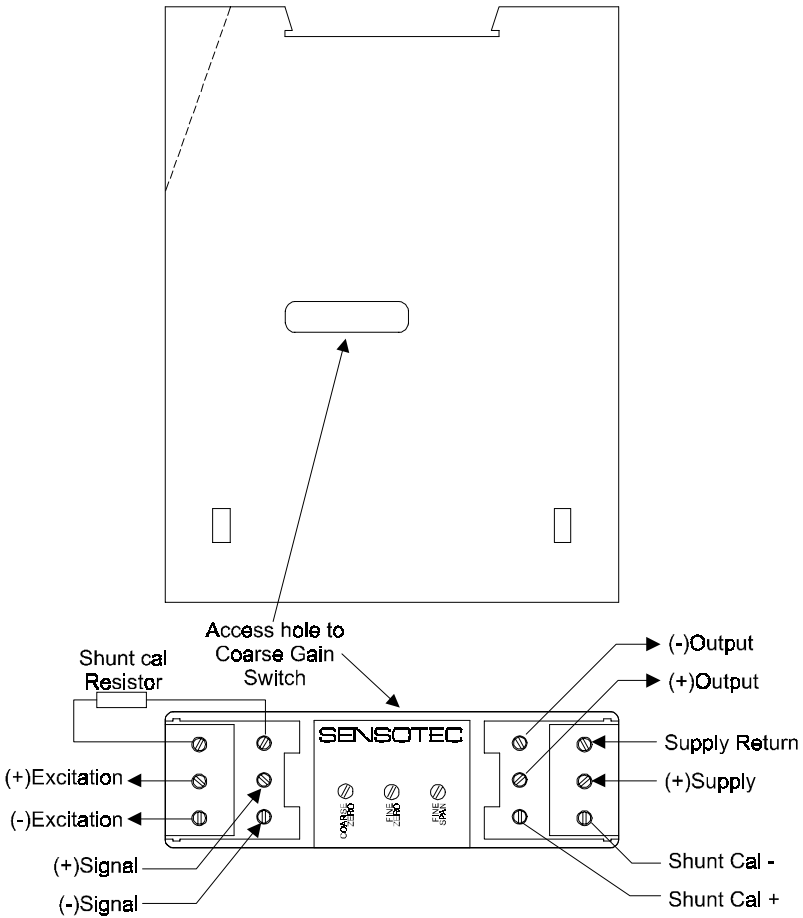

Figure 1-1: Layout and Wiring of Model WVV Transducer Amplifier

Chapter 2

INSTALLATION / SETUP

2.1 Mounting

The Model WV Transducer Amplifier snaps onto standard 35mm DIN rails. One side of the enclosure is slotted and the other is unslotted. Hook the unslotted side of the enclosure onto the rail, then press the slotted side firmly until it snaps onto the rail.

To remove the enclosure from the DIN rail, place a small flat-bladed screwdriver in the slot and turn it slightly. This releases the rail clamp, and the enclosure may be removed.

2.2 Wiring

2.2.1 General

The Model WV Transducer Amplifier should be wired according to Figure 1-1: "Layout and Wiring of Model WV Transducer Amplifier". If the transducer uses a shunt calibration resistor, install one with the value specified on the transducer's data sheet.

2.2.2 Model WT or WIS Weld Current Sensors

Refer to Figure 2-1: "Wiring to Model WT or WIS Weld Current Sensor" when wiring to Sensotec Model WT or Model WIS sensors. Excitation voltage should be set to 5.4 VDC for these applications.

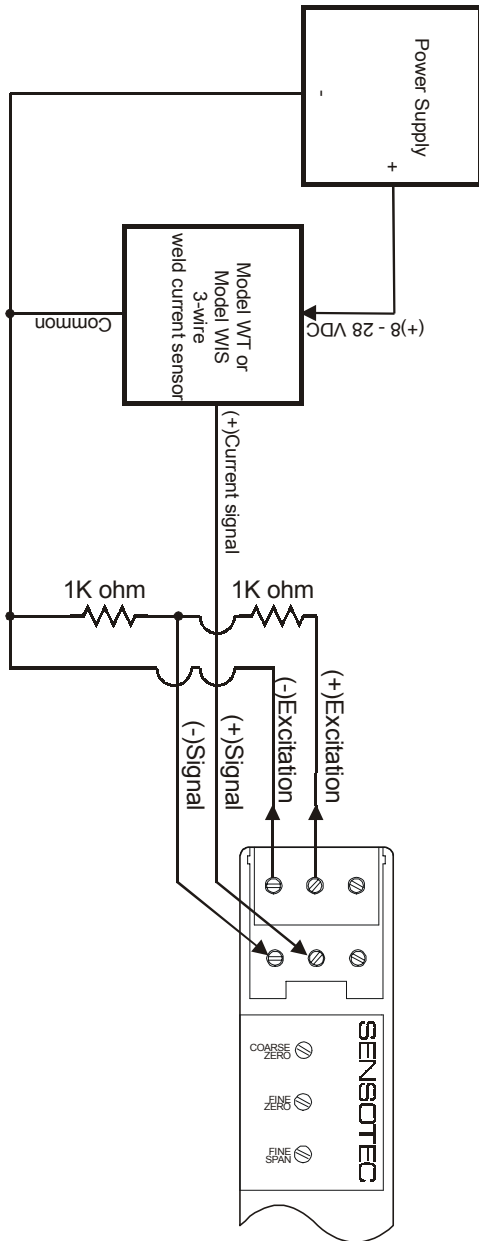

Figure 2-1: Wiring to Model WT or WIS Weld Current Sensor

2.3 Setup

Use the following procedure for setting up the excitation and the coarse gain:

1. Determine the EXCITATION VOLTAGE required by the transducer being used.
2. Set the EXCITATION SELECT JUMPER as shown in Figure 2-1. This requires removing the circuit board from the enclosure. The Amplifier usually is set at the factory for 9 VDC excitation.
3. Determine the full-scale output of the transducer in Volts from the transducer calibration sheet.
4. Set the COARSE GAIN SWITCH (See Fig.2-1 for location of switch) to the nearest "signal level" which matches the full-scale output of the transducer.

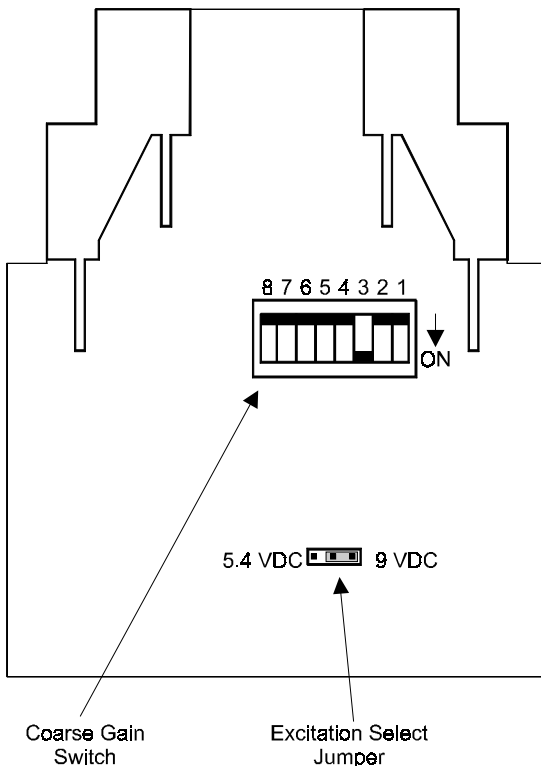

Figure 2-2: View of Circuit Board

Table 1: Coarse Gain Setup

SWITCH POSITION ON	SIGNAL LEVEL (VDC)
1	$\pm .1$
2	$\pm .25$
3	$\pm .5$
4	± 1
5	± 2.5
6	± 5

Chapter 3

CALIBRATION

3.1 Calibration

Step 1. Apply power and allow unit to stabilize for 10 minutes.

Step 2. With zero load or pressure on the transducer, adjust the ZERO potentiometers to indicate zero on the readout instrument or voltmeter connected to the output.

Step 3. Apply full scale pressure or load to the transducer and adjust the SPAN potentiometer to indicate full scale on the readout instrument or voltmeter.

Step 4. Re-check zero and full scale (repeat steps 2 & 3).

3.2 Using Shunt Calibration

Sensotec transducers feature a calibration technique called shunt calibration. This method applies a known resistance across one leg of the transducer, which simulates an output as if a load or pressure was applied to the transducer. When performing shunt calibration, the transducer should be at ZERO pressure or load. The full scale output and shunt cal output is found on the TRANSDUCER CALIBRATION SHEET. This information can be used to calibrate the amplifier's output voltage and the readout's display with the following equations:

TRANSDUCER CALIBRATION DATA

Full Scale Output = _____ V.

Shunt Resistor Value of _____ Ohms

Shunt Cal Output = _____ V.

FORMULA TO CALCULATE OUTPUT VOLTAGE

$\frac{\text{SHUNT CAL OUTPUT}}{\text{FULL SCALE OUTPUT}} \times \text{FULL SCALE VOLTAGE} = \text{OUTPUT VOLTAGE}$

_____ X _____ = _____

FORMULA TO CALCULATE DISPLAY UNITS

$\frac{\text{SHUNT CAL OUTPUT}}{\text{FULL SCALE OUTPUT}} \times \text{FULL SCALE UNITS} = \text{DISPLAY UNITS}$

_____ X _____ = _____

- Step 1. Apply power and allow the amplifier to warm up.
- Step 2. With zero load or pressure on the transducer, adjust the ZERO potentiometer to indicate zero on the readout instrument or voltmeter.
- Step 3. Connect a jumper (or close a switch) across the (+)Shunt Cal and (-)Shunt Cal terminals as shown in the figure below. Adjust the SPAN potentiometer to

the calculated voltage or calculated units on the readout instrument or voltmeter.

Step 4. Disconnect the shunt cal jumper (or release the shunt cal switch) and repeat steps 2 & 3 if needed.

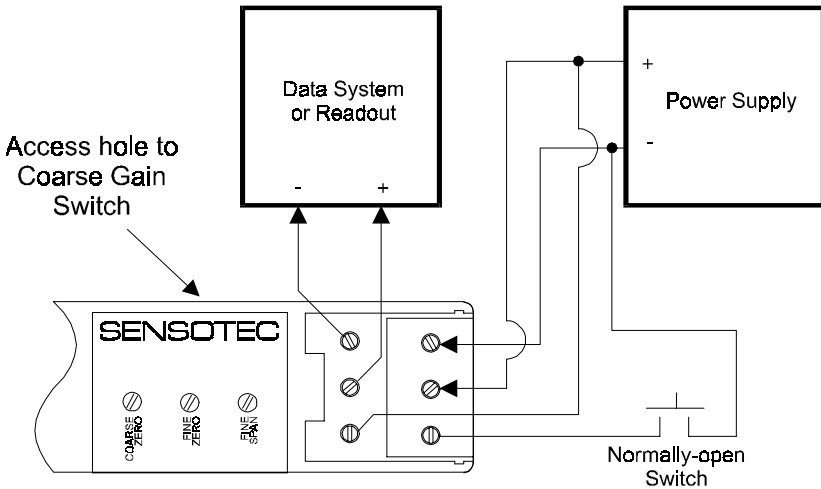

Figure 3-1: Shunt Cal Wiring Example

Chapter 4

WARRANTY / REPAIR POLICY

4.1 Limited Warranty on Products

Any of our products which, under normal operating conditions, proves defective in material or workmanship within one year from the date of shipment by SENSOTEC, will be repaired or replaced free of charge provided that you obtain a return material authorization from SENSOTEC and send the defective product, transportation charges prepaid with notice of the defect, and establish that the product has been properly installed, maintained, and operated within the limits of rated and normal usage. Replacement product will be shipped F.O.B. our plant. The terms of this warranty do not extend to any product or part thereof which, under normal usage, has an inherently shorter useful life than one year. The replacement warranty detailed here is the buyer's exclusive remedy, and will satisfy all obligations of SENSOTEC whether based on contract, negligence, or otherwise. SENSOTEC is not responsible for any incidental or consequential loss or damage which might result from a failure of any SENSOTEC product. This express warranty is made in lieu of any and all other warranties, express or implied, including implied warranty of merchantability or fitness for particular purpose. Any unauthorized disassembly or attempt to repair voids this warranty.

4.2 Service Under Warranty

Advanced authorization is required prior to the return to SENSOTEC. Before returning the items, either write to the Customer Service Department c/o SENSOTEC, Inc., 2080 Arlingate Lane, Columbus, Ohio 43228, or call (800) 848-6564 with: 1) a part number; 2) a serial number for the defective product; 3) a technical description* of the defect; 4) a no-charge purchase order number (so products can be returned to you correctly); and 5) ship and bill addresses. Shipment to SENSOTEC shall be at Buyer's expense and repaired or replacement items will be shipped F.O.B. our plant in Columbus, Ohio. Non-verified problems or defects may be subject to an evaluation charge. Please return the original calibration data with the unit.

4.3 Non-Warranty Service

Advance authorization is required prior to the return to SENSOTEC. Before returning the item, either write to the Customer Service Department c/o SENSOTEC, Inc., 2080 Arlingate Lane, Columbus, Ohio 43228, or call (800) 848-6564 with: 1) a model number; 2) a serial number for the defective product; 3) a technical description* of the malfunction; 4) a purchase order number to cover SENSOTEC's repair cost; and 5) ship and bill addresses. After the product is evaluated by SENSOTEC, we will contact you to provide the estimated repair costs before proceeding. Shipment to SENSOTEC shall be at Buyer's expense and repaired items will be shipped to you F.O.B., our plant in Columbus, Ohio. Please return the original calibration data with the unit.

4.4 Repair Warranty

All repairs of SENSOTEC products are warranted for a period of 90 days from date of shipment. This warranty applies only to those items which were found defective and repaired, it does not apply to products in which no defect was found and returned as is or merely recalibrated. Out of warranty products may not be capable of being returned to the exact original specifications or dimensions.

* Technical description of the defect: In order to properly repair a product, it is necessary for SENSOTEC to receive information specifying the reason the product is being returned. Specific test data, written observations on the failure and the specific corrective action you require is needed.