

■

Model 1202B Power Measurement System

Applies to Part Numbers in the Series: 060-55072-1626-01

Calibrated Set Number: 5631-1626-8001

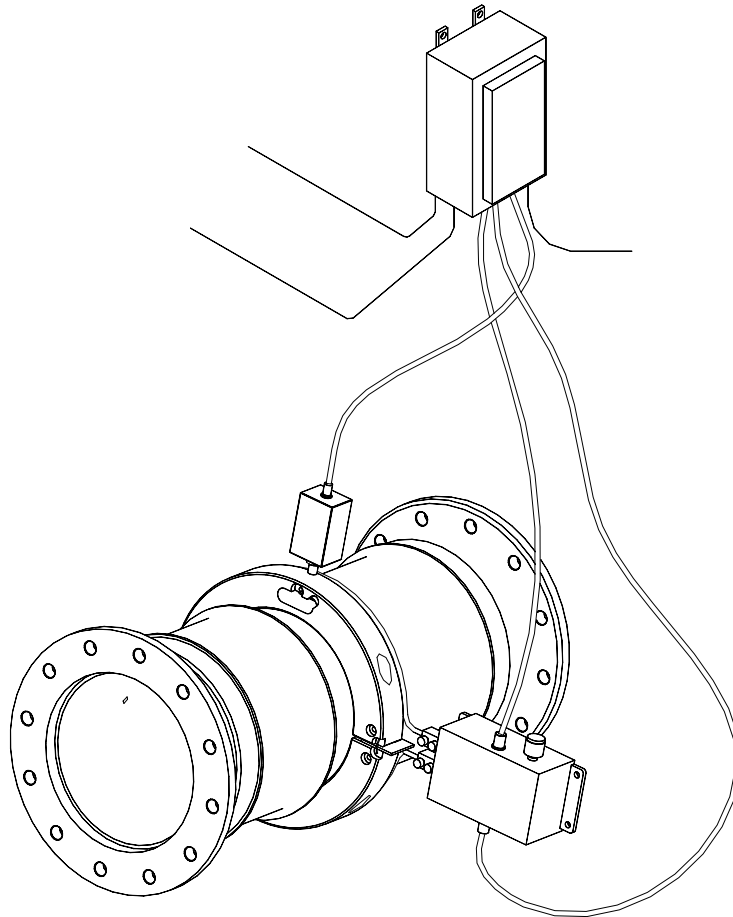

WDC Wireless Data Corporation

Product of Sensotec Inc.

Sensotec, Inc.
2080 Arlingate Lane
Columbus, Ohio 43228 USA
Copyright © 2002 by Sensotec, Inc. all rights reserved
Telephone: (614)850-5000
FAX: (614)850-1111
Toll Free: 1-800-848-6564
E-mail: service@sensotec.com
WWW: <http://www.sensotec.com>

Model 1202B Power Measurement System

Sensotec Document Number: 008-0639-00 Rev. A

Rev. -: March 2003

Rev. A: May 2003, 03-194; Table 1-1 Updated calibration specifications
Analog Recorder Output; Torque was 175,000 in-lb, HP was 15,000 HP
Channel #1 Horsepower; HP was 15,000 HP; Sections 4.4.6, 4.9.1, 4.9.2
numerous revisions.

IMPORTANT

It is recommended that you read this document thoroughly before applying power to this unit.



CAUTION: The operator of this instrument is advised that if the equipment is used in a manner not specified in this manual, the protection provided by the equipment may be impaired.



CAUTION: Only qualified, personnel who are aware of the hazards involved should remove the covers or connect external wiring to the instrument.

Sensotec and the Sensotec logo are registered trademarks of Sensotec, Inc.

Printed in U.S.A.



Contents	3
List of Figures	7
List of Tables	9
Chapter 1	
General Information	11
1.1 Introduction	11
1.2 Description	11
1.3 Relationship Of Units	11
1.3.1 Shaft-Mounted Components	11
1.3.2 Stationary Components	11
Chapter 2	
Operations	17
2.1 Introduction	17
2.2 System Operation	17
2.2.1 Shaft Mounted Components	17
2.2.2 Non-Rotating Equipment	17
2.2.3 Emergency Turn-Off	17
2.3 Operation Of Protective Devices	18
2.4 Modes Of Operation	18
2.4.1 Normal Mode	18
2.4.2 Calibration Check Mode	18
2.4.2 Torque Output Check	18
2.4.2 Horsepower/RPM output check.	19
Chapter 3	
Functional Description	23
3.1 Introduction	23
3.2 Overall Description	23
3.2.1 User Provided Torque Sensor	23
3.2.2 Transmitter Module - Model 2120B	23
3.2.3 High Speed Collar - Model 2126A	24
3.2.4 Power Separation Unit (PSU), Model 1211D	24
3.2.5 RPM Probe, Model 1213A	24
3.2.6 Readout Electronics, Model 1642A	24
3.2.6 Option PCB	24
3.2.6 Filter PCB	24
3.2.6 Power Supply PCB	24
3.2.6 Receiver	24
Figure 3-1: Period PCB	25
Figure 3-1: HP/RPM PCB	25
3.3 Functional Description	26
3.3.1 Torque Detection	26
3.3.2 Torque Signal Conversion	26
3.3.3 RPM Detection	26

3.3.4 RPM Signal Conversion	26
3.4 Conditioning / Processing	26
3.4.1 Torque Output Voltage	26
3.4.2 RPM Output Voltage	27
3.4.3 Horsepower Data	27

Chapter 4

Installation	29
4.1 Introduction	29
4.2 Equipment Inspection	29
4.2.1 Unpacking	29
4.2.2 Handling	29
4.3 System Familiarization	30
4.3.1 User Provided Torque Sensor	31
4.3.2 Transmitter Module - Model 2120B	31
4.3.3 High Speed Collar - Model 2126A	31
4.3.4 Power Separation Unit (PSU) - Model 1211D	31
4.3.5 RPM Probe - Model 1213A	31
4.3.6 Readout Electronics - Model 1642A	31
4.4 Operational Familiarization	36
4.4.1 Bench Checkout Criteria	36
4.4.2 Collar Assembly	38
4.4.3 Transmitter Wiring	38
4.4.4 PSU/Antenna Assembly	38
4.4.5 Cabling and Power-up	39
4.4.6 PSU Tuning and Power-Up	39
4.4.7 Torque Zero and Gain adjustment	41
4.5 Installation	43
4.6 Model 2126A High Speed Collar	43
4.6.1 Collar Installation Tools	45
4.6.2 Collar Location	45
4.6.3 Collar Assembly	45
4.6.4 Rotating Antenna Wiring	45
4.7 Model 1213A RPM Probe	46
4.8 Model 1211D PSU / Antenna	46
4.8.1 Antenna Clearance	46
4.8.2 PSU Mounting	47
4.9 PSU Power Tuning	47
4.9.1 Pre-Tuning Conditions	47
4.9.2 Equipment Required	47
4.9.3 Power Tuning Procedure	48

Chapter 5

Calibration	51
5.1 Introduction	51
5.2 Power Definitions And Formulas	51
5.3 Calibration - Overview	51
5.4 Application Review	52
5.5 Universal RPM - Range Select P/N 5631-230 ..	52
5.6 Install Display Scaling Resistors	53
5.6.1 RPM & HP Calculator - P/N 4017-122	54
5.6.2 Torque Filter P/N 5631-062	55
5.7 Torque Calibration Overview	56



5.7.1 Setting Transmitter Gain	56
5.7.2 Other Bridges, Other Strain Levels	57
5.8 Setting Transmitter Zero By Balancing The Bridge	58
5.9 Setting Torque Receiver Gain And Calibration Check	58
5.9.1 Receiver Calibration	58
5.9.2 Calibration Sequence	59
5.10 Setting Torque Calibration Check (Optional) . .	59
5.11 Polarity Reversal Of Torque Record Output . . .	60
Warranty/Repair Policy	61
Limitation of Remedy and Disclaimer of Warranty	61
Obtaining Service Under Warranty	61
Obtaining Non-warranty Service	61
Repair Warranty	61

List of Figures



Figure 1-1: Model 1202B Power Measurement System	12
Figure 2-1: Model 1642A Electronics Readout	19
Figure 2-2: Model 1213A RPM Pickup	20
Figure 2-3: Model 1211D Power Separation Unit (PSU)	21
Figure 3-1: Model 1642A Card Slots	25
Figure 4-1: T-Circuit Bridge Simulation	30
Figure 4-2: Model 2120B Transmitter Pin Functions	30
Figure 4-3: Typical 2126A Collar Installation Assembly	32
Figure 4-4: Operating RPM Limit vs. Shaft Size	32
Figure 4-5: Model 1211D PSU Installation Assy	33
Figure 4-6: Model 1213A RPM Pickup Installation	34
Figure 4-7: Model 1642A Electronics Readout	35
Figure 4-8: Rotating Antenna Wiring	37
Figure 4-9: Transmitter Installation and T-Circuit Wiring	38
Figure 4-10: Model 1202B Interconnect Cabling	40
Figure 4-11: Model 1642A Electronics Readout Switches and Controls	42
Figure 4-12: Model 1211D PSU Internal View	43
Figure 4-13: Receiver Zero and Gain Adjustment	44
Figure 4-14: Sensor Connection and Bridge Balance	46
Figure 5-1: Universal RPM PCB	53
Figure 5-2: HP / RPM Calculator PCB	54
Figure 5-3: Filter PCB	55
Figure 5-4: Receiver PCB	55
Figure 5-5: Sensor Bridge / 2120B Transmitter Interface	57
Figure 5-6: Resistance vs. Microstrain Input to 2120B Transmitter	58

List of Tables



Table 1-1: 1202B System Specifications	13
Table 1-2: Model 1202B Parts List	14
Table 1-3: Sensor / Demodulator Calibrated Set Parts List	14
Table 1-4: Accessory Kit Parts List	15
Table 4-1: Model 2120B Transmitter Pin Functions	30
Table 4-2: Model 1642A Electronics Readout Parts List	36
Table 4-3: Receiver Zero and Gain Designators	44

Chapter 1

General Information

1.1 Introduction

This technical manual provides operation, functional description, parts lists, installation and calibration instructions for the 1202B Power Measurement System.

1.2 Description

The purpose of the 1202B System is to obtain torque and RPM data from high or low speed rotating shafts and use these inputs to compute and display power in real time.

The 1202B system consists of a clamp-on high-speed collar machined to fit the outside diameter of the power transmission shaft. Each high-speed collar contains a built-in antenna, metal tabs for shaft speed detection and a machined pocket to hold the transmitter module. A bulkhead mounted electronics readout unit provides induction power to a stationary power separation unit with loop antenna fitted around, but not touching, the clamp-on collar. The loop antenna also receives the transmitter torque signal. The torque signal along with the shaft speed signal is routed to the electronics. These units together provide the means for measuring torque and RPM. The readout electronics can also be set-up to display torque, RPM and computed horsepower in engineering units.

1.3 Relationship Of Units

1.3.1 Shaft-Mounted Components

The clamp-on collar and transmitter module together rotate with the shaft and power a user provided four-arm strain gage bridge. They also transmit the output signal to the non-rotating electronics.

NOTE: The strain gages, their installation and calibration is the responsibility of the system user.

1.3.2 Stationary Components

The electronics readout assembly contains the circuitry which converts the signals from the torque and RPM sensors into voltages that are proportional to torque and RPM. These signals are used to display scaled torque, RPM and computed horsepower.

In addition the system can also provide:

- Voltage level outputs for Remote Displays or Recorders
- 4-20 mA current outputs of Torque, RPM and HP

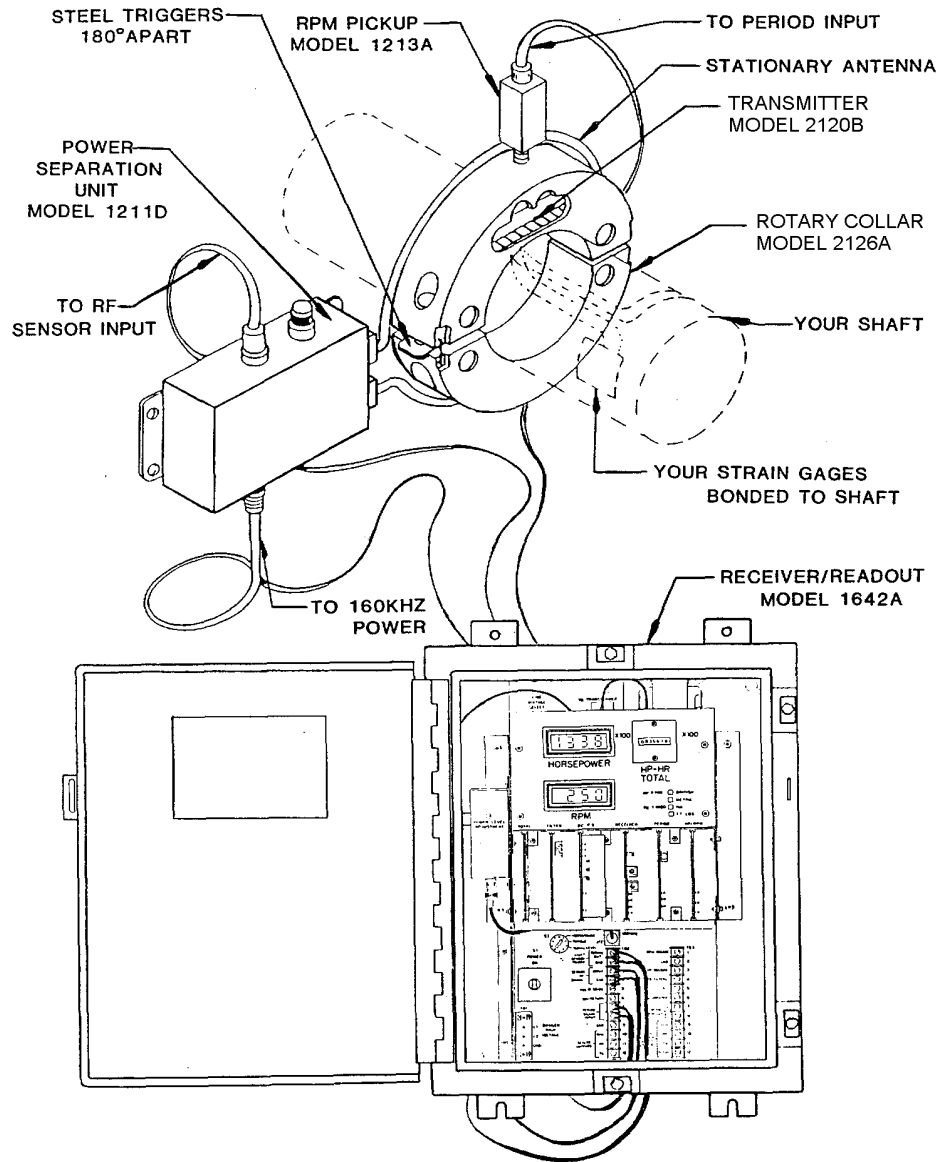

1-u

Figure 1-1: Model 1202B Power Measurement System

Table 1-1: 1202B System Specifications

Manufacturer	Wireless Data Corp., A Sensotec Company
FSCM	51518
Nomenclature	Power Measurement System
Model	1202B
System	
Accuracy - Torque	±.75% FS
RPM	±.10% FS
Horsepower	± .25% FS
Torque Sensor - Linearity	±0.02% FS
Repeatability	±0.01% FS
Frequency Response	DC to 100 Hz (3db limit) Modifiable to long periods based on filter board setting
Effects of Temperature - On Zero	±.01% FS/° C
On Span	±.005% FS/° C
Compensated Temperature Range	5° to 60° C (40° to 140° F)
Operating Temperature Range	10° to 50° C (50° to 122° F)
Usable Temperature Range	-25° to 75° C (5° to 167° F)
Analog Recorder Outputs - Torque	±5 VDC Scaled (plus 100% over range) 0 VDC = 0 ft.-lb. 5.0 VDC = 18,230 ft.-lb.
RPM	0 to 10 VDC Scaled (plus 10% overrange) 0 VDC = 0 RPM 10 VDC = 6000 RPM
Horsepower	0 to 10 VDC Scaled (plus 10% overrange) 0 VDC = 0 HP 10.0 VDC = 20,826 HP
Recorder Output Impedance	< 1.0 ohm resistive nominal
Auxiliary Outputs	Two (2) 4 - 20 mA channels. DC Isolation is ≤ 100 Mohm with a 28 VDC source.
Channel #1 - Horsepower	4 mA = 0 HP 20 mA = 20,826 HP
Channel #2 - RPM	4 mA = 0 RPM 20 mA = 6000 RPM.
Shaft Diameter	6.40 in (162.6 mm)
Induuced Power Frequency	160kHz nominal
Minimum Strain for FS Rereading	1000 Ohm Bridge - 500 in./in ±20% 350 Ohm Bridge - 175 in./in ±20%
Power Requirements	115/230 VAC (-15% to +10%), selectable. 50 to 400 Hz. Power consumption, 100 VA maximum
Shipping Weight	40 to 50 lb.

Table 1-2: Model 1202B Parts List

Qty	ITEM NAME	PART NUMBER	OVERALL DIMS (INCH)	Wt. (LB)
1	Model 1642 Electronic Readout	5631-150-01	24 X 20 X 15	28
1	Model 1211D Power Separation Unit	4017-500-01	6LX4WX2H	3
1	Model 2126A Collar Assy	4017-915-01	Sized To Fit 6.40 Inch (162.6 mm) Shaft	2
1	Model 1213A RPM Pickup	4017-238-01	4X1.5X1.5 1.0	1
1	Stationary Antenna	N/A	5/32 Diameter Brass Wire Fabricatd To Fit Collar.	1
3	Test Cable	55069-010	15'	10
2	Bolt, High Strength	4017-518-05	5/16-24 X 3.0	.5
2	Nut, Locking	95870-258	5/16-24	.5
2	Washer, Special	4017-061-02	5/16 Dia	.1
2	RPM Trigger	4017-102-01	1.25 X .60 .090	.1
1	Sensor / Demodulator Calibrated Set	5631-1625-8001	See Table 1-3 for Part Numbers	N/A
1	Accessory Kit	4017-995-01	See Tabel 1-4 for Part Numbers	N/A
1	Instruction Manual	008-0639-00		N/A

Table 1-3: Sensor / Demodulator Calibrated Set Parts List

Qty	ITEM NAME	PART NUMBER
1	Dual Channel 4-20 mA Isolated Output PCB	027-0745-00
1	Receiver PCB, 16.0 MHz	5631-198-26
1	Long Period Filter PCB	5631-062-01
1	Universal RPM, Period PCB	5631-230-01
1	Transmitter, 2120B 16 MHZ	54775-160
1	Horsepower / RPM Calculator PCB	4017-122-01

Parts on this list must be purchased as a calibrated set.

Reference calibration setup number 8001

Table 1-4: Accessory Kit Parts List

Qty	ITEM NAME	PART NUMBER
1	7/16" 12-Point Deep Well Socket	90868-002
1	1/4" Allen Wrench (L-Hex Key)	90868-003

2.1 Introduction

This chapter describes the operation of the Model 1202B Universal Power Measurement System. The 1202B system consists of shaft mounted units which rotate with the shaft and stationary units at or near the shaft. A user-supplied strain gage bridge receives power from the transmitter on the shaft and transmits an RF signal to the stationary electronics. The electronic readout contains power supplies, plug-in signal conditioning, data displays and outputs for remote read-outs or recorders.

When energized, the system functions independent of an operator. Built-in calibration check circuitry can be activated at any time to verify that all local and remote displays and outputs are functional.

2.2 System Operation

2.2.1 Shaft Mounted Components

The shaft mounted components have no displays or indicators. The strain gage bridge is wired to the transmitter module located in a pocket in the high-speed collar. Power for the transmitter and bridge are provided via a single wire loop antenna fabricated into the outer surface for the collar. Torque information in the form of a modulated RF signal is broadcast back through this same antenna. Shaft speed is obtained from two magnetic RPM triggers that are secured to each collar. The RPM probe senses the triggers as the shaft rotates. There are no hazardous voltages on the transmitter pins or antenna wire connection during operation.

2.2.2 Non-Rotating Equipment

Figure 2-1: on page 19 shows the controls and indicators of the Model 1642A Electronics Readout. Under normal use the equipment remains powered-up 24 hours a day. There is no stand by. The system is turned on and off from within the readout enclosure using the Power Switch (3). Non- hazardous power to shaft mounted components is provided via the 160 Khz adjustable power supply (2).

Figure 2-2: on page 20 illustrates the Model 1213A RPM pickup. Figure 2-3: on page 21 illustrates the Model 1211D Power Separation Unit (PSU). The PSU supports the stationary antenna and provides a place to tune the antenna for resonance. Operating the antenna at resonance results in the very efficient power system and a minimum of interfering RF noise. The shape of the stationary antenna is not critical. It should be positioned within 1/2 inch of the rotating collar to avoid power losses that may effect normal operation.

2.2.3 Emergency Turn-Off

The equipment can be turned off and on at any time during an emergency without damage to the equipment. For maximum data precision there is a thirty minute warm-up period.

2.3 Operation Of Protective Devices



WARNING: Ensure the POWER SWITCH, Figure 2-1 (3) is in the off position before servicing. Failure to heed this warning could allow servicing personnel to receive a hazardous electrical shock.

The Model 1642A Readout is protected by a circuit breaker operating on both sides of the AC power line. 160 KHz power to the PSU is protected by current limit circuitry and a fast blow fuse. See Figure 2-1 (3) and (10).

The 160 kHz power fuse, Figure 2-1 (10), is of the 3AG type rated at 2 amps.

2.4 Modes Of Operation

NOTE: The following discussion on operational modes presumes all components of the 1202B system have been installed, calibrated and tuned per instructions contained within this manual and the system is fully functional.

Normal mode of operation of the 1202B requires no user interaction. All indicators are on continuously. The following paragraphs identify normal mode and calibration mode switch positions. Reference Figure 2-1: on page 19 for switch locations.

2.4.1 Normal Mode

- a) Receiver PCB ZERO Switch (1) down.
- b) Receiver PCB CAL Switch (2) down.
- c) Selector Switch (3) in HORSEPOWER position.
- d) Filter PCB Selector Switch (4) position 3.
- e) Period PCB Switch (6) not pushed.

2.4.2 Calibration Check Mode

Torque Output Check

- a) Selector Switch (3) to TORQUE position
- b) Filter PCB Selector Switch (4) to position 1.
- c) Receiver PCB ZERO Switch (1) up.
- d) Display (5) should show zero +1 digit.
- e) Voltage at TB3-4 (TO Record) should be zero ± 0.005 VDC
- f) Receiver PCB CAL Switch (2) up.
- g) Display (5) should now show Torque Full Scale ± 1000 Torque units.
- h) Voltage at TB3-4 should now be $+5.000 \pm 0.005$ VDC
- i) Restore all switches to Normal Mode positions

Horsepower/RPM output check.

- a) Complete Torque Output check steps a) through h).
- b) Selector Switch (3) to HORSEPOWER position.

NOTE: Display (5) may show any value at this step depending upon actual shaft RPM.

- c) Press Period PCB Switch (6) and hold until instructed to release.
- d) Display (5) should show Horsepower Full Scale ± 100 Horsepower units.
- e) Display (7) should show RPM full scale ± 1 RPM
- g) Voltage at TB3-1 (RPM Record) should be ± 10.00 volts.
- h) Release Period PCB Switch (6).
- i) Restore all switches to Normal Mode Positions.

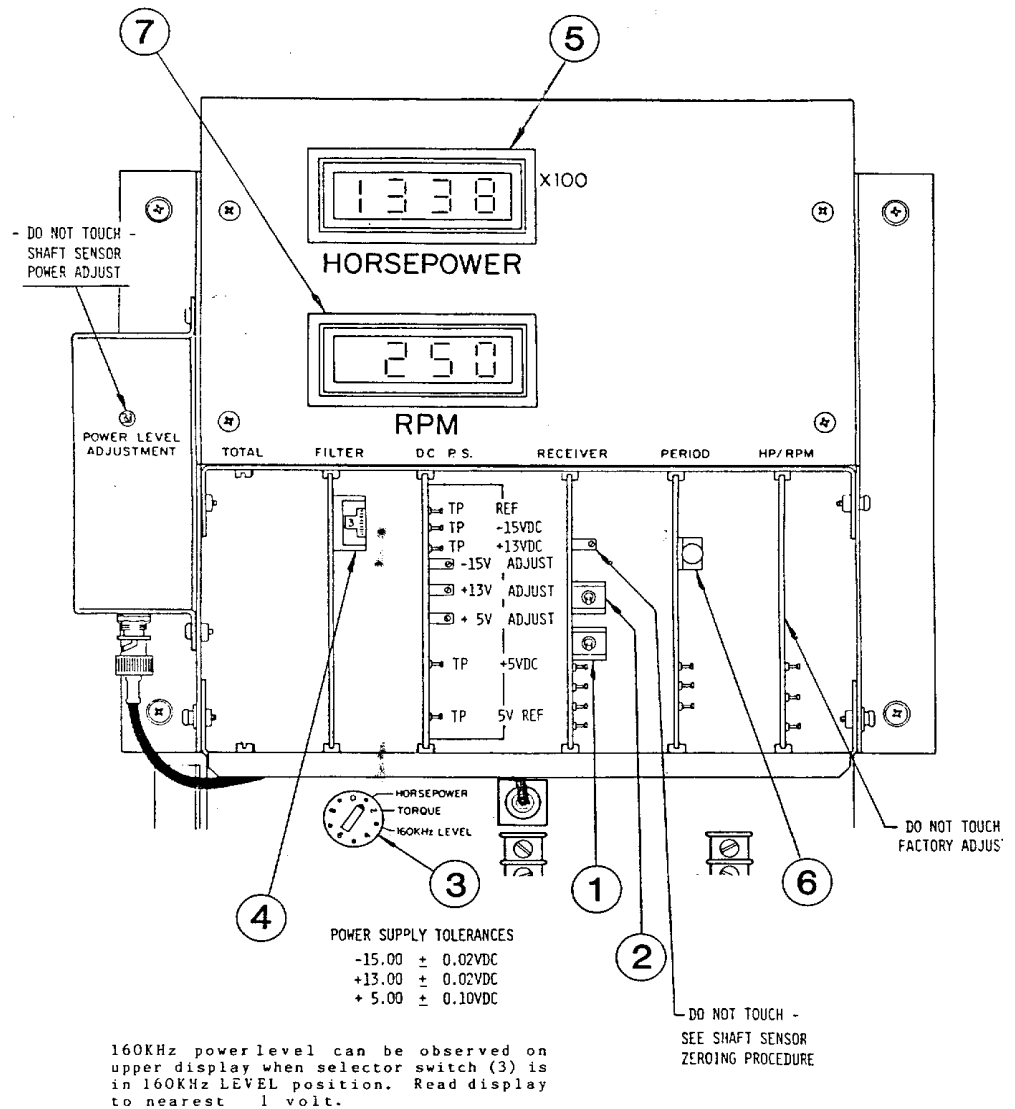

Figure 2-1: Model 1642A Electronics Readout

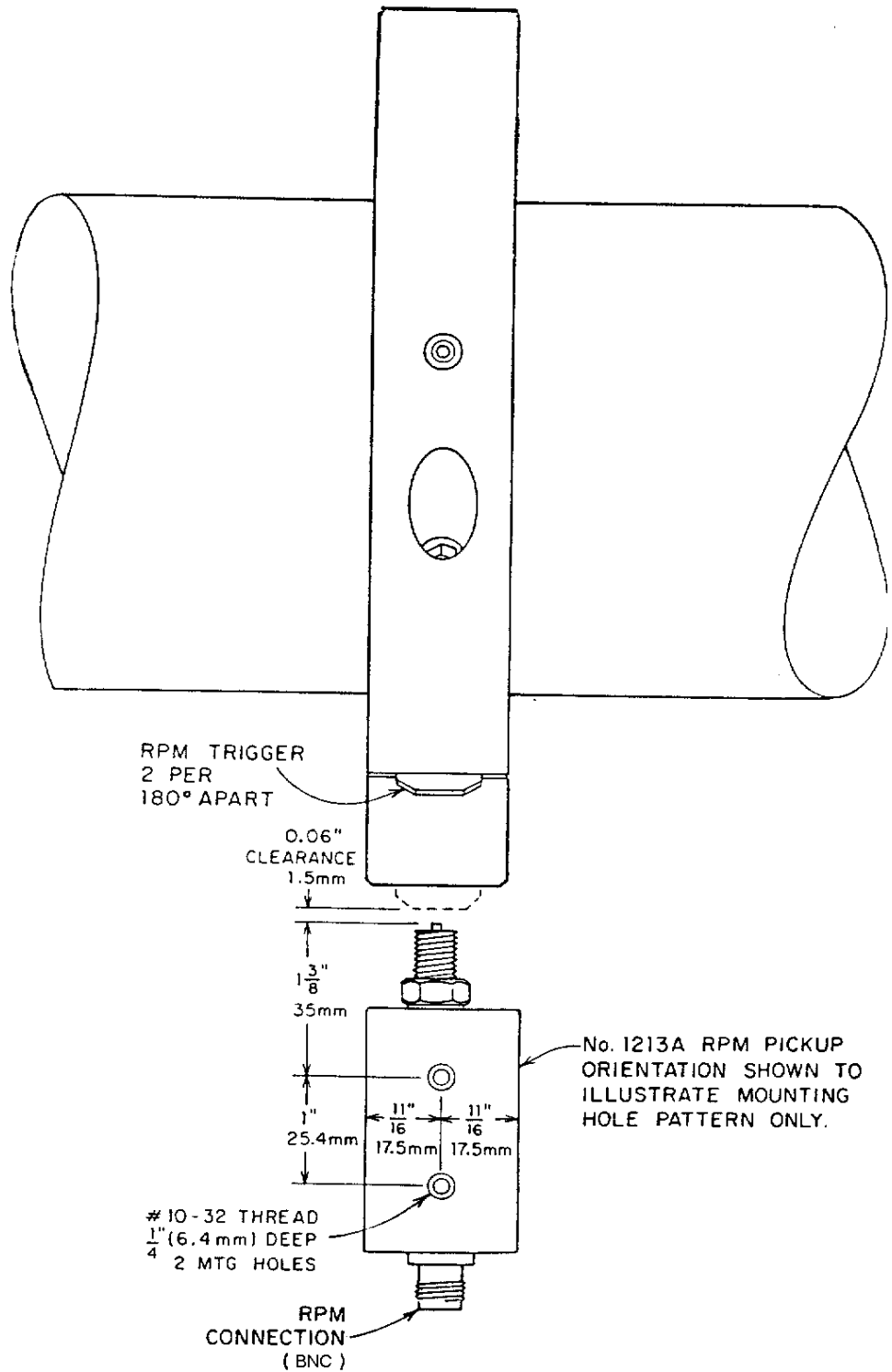

Figure 2-2: Model 1213A RPM Pickup

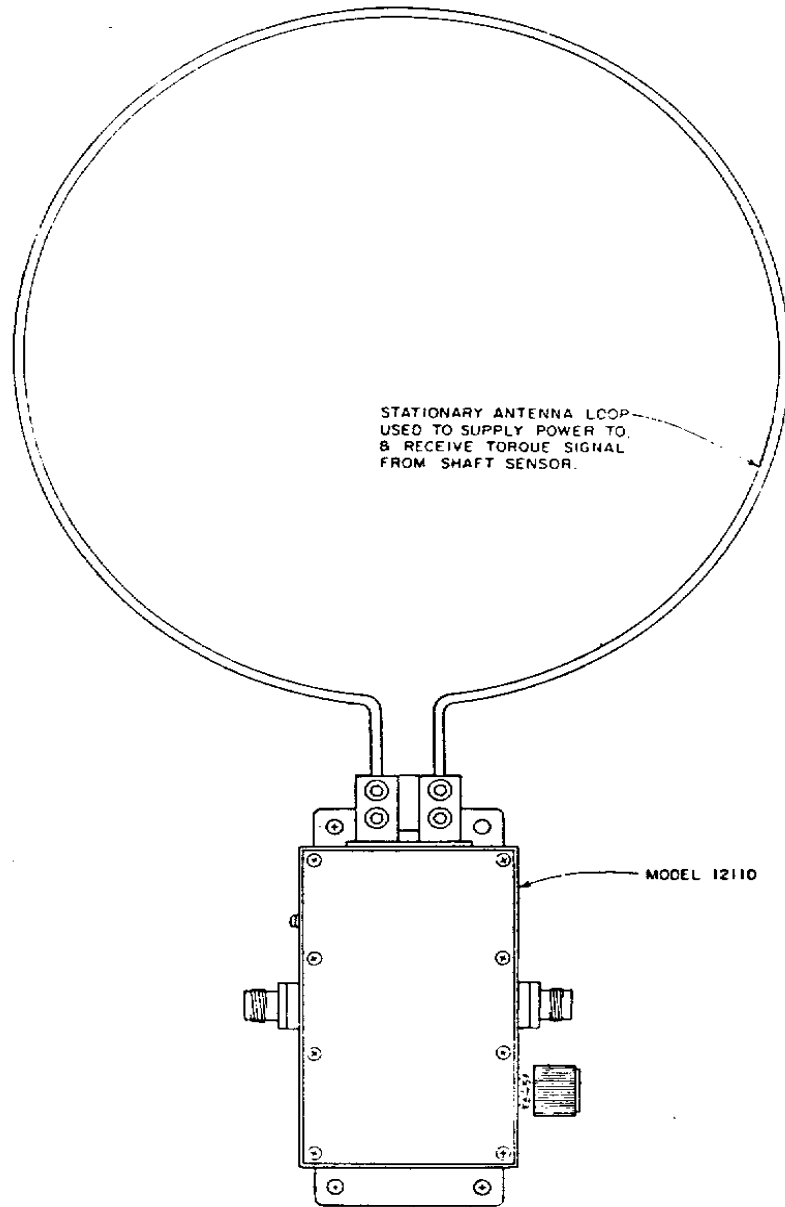

Figure 2-3: Model 1211D Power Separation Unit (PSU)

3.1 Introduction

This chapter describes the overall function of the 1202B Power Measurement System and relationships between rotating and stationary components. and an overall functional description of the system.

3.2 Overall Description

The 1202B Power Measurement System consists of rotating and stationary components as follows:

Rotating Components:

- User-provided strain gage bridge
- High speed clamp-on collar assembly, Model 2126A (includes Transmitter Module, Model 2120B)

Stationary Components:

- Power Separation Unit, Model 1211D (with antenna loop.)
- RPM Pickup, Model 1213A
- Electronics Readout, Model 1642A

3.2.1 User Provided Torque Sensor

The 1202B System is designed to utilize a Wheatstone bridge as the torque sensor and data source for the 2120B transmitter. The bridge must be balanced and within the impedance limits of the general specifications in **Table 1-1**, "**1202B System Specifications**", **page 13**. The transmitter has a 5 VDC nominal power source. Common mode level of the input signals to the transmitter must be nominally 2.5 volts.

3.2.2 Transmitter Module - Model 2120B

The transmitter module is installed in a machined pocket of the 2126A high speed collar. Two solder pins on the transmitter must be connected the collar antenna. Additional connections on the transmitter provided for the torque bridge or sensor are regulated DC common, plus signal input and minus signal input. There are two built in levels of signal sensitivity available for the torque signal. Any signal level greater than stated in Table 1-1 can be accommodated by adding a resistor to the input circuit. The torque bridge input is zeroed by shunt balancing, if necessary.

3.2.3 High Speed Collar - Model 2126A

The collar is machined to match the shaft size of the power transmission system. The cross section of the collar is approximately 1.25 X 1.25 inches. The collar is made of high strength epoxy - fiberglass laminate. A factory installed power coupling antenna is buried in its outer circumference. Solder pin connections are provided at the split points of the collar to enable easy completion of the loop after installation. Two 0.09 thick steel RPM probe triggers are epoxied into a recess in each half of the collar. High strength bolts are used to clamp the collar the shaft. The bolts also pass through a hole in the RPM triggers assuring that they do not come loose.

3.2.4 Power Separation Unit (PSU), Model 1211D

The PSU is a flange mounted box which contains an impedance matching transformer and resonating capacitance decade switch. This device matches the high voltage low current 160 kHz oscillator power source to the low voltage high current single loop stationary antenna inserted into connections of the 1211D. The stationary antenna is inserted into connections of the 1211D. The stationary antenna will only provide sufficient power to the 1216 transmitter at resonance. Achieving resonance requires selecting a specific capacitor during system set-up. Terminals are available under the cover for selection and installation of this "gross" capacitor. The built-in decade switch provides additional fine tuning. In addition to transferring power to the transmitter the antenna/PSU also receives the RF data signal and routes it via coaxial cable to the receiver for processing.

3.2.5 RPM Probe, Model 1213A

The RPM pickup has a sensing probe which detects the passing of any magnetic material such as the triggers installed in the collar. There are two triggers in each high speed collar assembly for balance and the 1213A pickup will output two pulses per revolution of the shaft. Coaxial cable is used to route the 1213A signal to the receiver for processing. The probe has threaded holes for mounting. The probe tip must be located 0.06 inches from the passing triggers in the collar.

3.2.6 Readout Electronics, Model 1642A

The Readout Electronics Assembly is contained in a bulkhead mountable enclosure and houses plug-in circuit cards which convert the transmitter torque signals and pulse RPM signals into meaningful scaled data. The plug-in circuit card housing contains six usable slots. See "Model 1642A Card Slots" on page 25. One slot is available for optional functions. Viewing the housing from left to right the standard card functions as follows:

Option PCB

Alternate storage location of the extender card and location of optional 4-20 mA Isolated Output PCBs

Filter PCB

Gain of 1.000 - Used to smooth dynamic torque data when high frequency information is not desired. A five position thumb activated switch provides for varying amounts of filtering as the user feels necessary. This card also contains the voltage divider circuit used to set the scaling of the torque signal to engineering units for viewing on the digital display.

Power Supply PCB

This triple output supply provides regulated plus and minus voltages to all cards and the 160 kHz power supply. The five volt supply is used to power the digital displays.

Receiver

Converts the RF signal from the transmitter into a voltage proportional to torque. This card contains zero and gain controls with terminals available to add a fixed gain resistor. The output signal polarity can be reversed without affecting the circuit calibration. A toggle switch activated calibration zero check and full scale check circuit is also on the card.

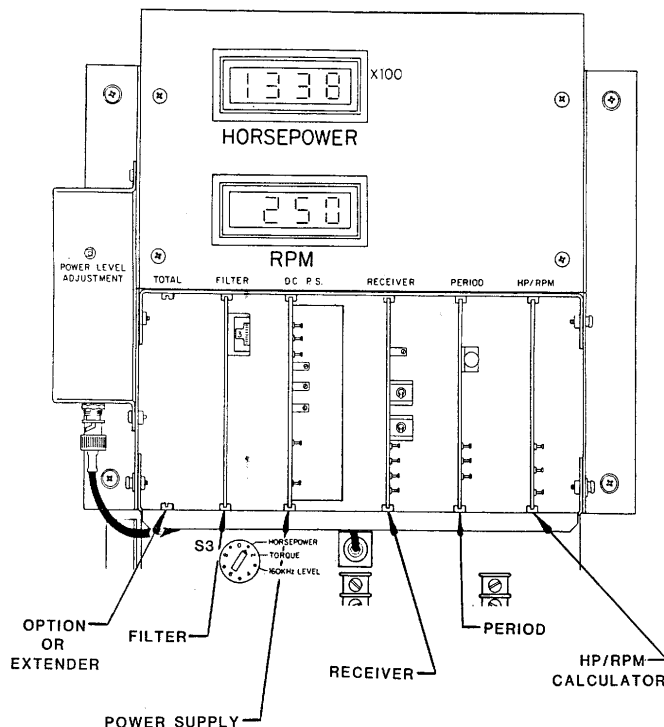

Figure 3-1: Model 1642A Card Slots

Period PCB This self calibrating card converts the two pulses per revolution period input into an analog voltage proportional to the reciprocal of RPM. Scaling on this assembly is accomplished by inserting bus wire jumpers in numbered locations during system setup. The circuit operates from 10% to 110% of the selected range. The selected range can be between 0 to 50 RPM up to 0 to 8000 RPM. A momentary push button at the front edge of the card yields full scale out of the card for a calibration check.

HP/RPM PCB T4 is dual analog calculator circuit converts the period voltage signal into one directly proportional to RPM. It also combines the RPM signal and the torque signal with a constant to produce instantaneous power. Two voltage divider circuits are available to provide scaling of RPM and horsepower so the user may view engineering units on the digital displays.

The HP/RPM calculator card is adjusted at the factory to accept specific voltages representing torque and RPM full scale. Only these voltages will produce the correct result out of the calculator. The RPM circuit on the Period board produces the correct voltage when the user selects the desired range and installs the jumpers. However, the torque signal which originates on the Receiver card must be setup to 5.00 Volts during calibration procedures. This allows for 100% over ranging on the torque input. High torque at low RPM's is a common occurrence and the system has been designed to accommodate 100% torque overrange. Do not attempt to change the over range as system function will be lost.

The voltage level outputs of torque, RPM and power are available at terminals in the enclosure. An additional unfiltered torque output is available for recording torsional vibration while the filter smooths the data for easy viewing on the digital display. The upper display serves to view power, torque or power level of the 160 kHz power supply. Switch S3 selects the desired function. The RPM display is dedicated.

3.3 Functional Description

The 1202B Power Measurement System utilizes three basic functions:

- Torque and RPM - Parameter Detection
- Parameter Signal Conversion
- Conversion Signal - Conditioning/Processing

3.3.1 Torque Detection

A data transmitter receives the output of the strain gage bridge and converts this signal to a modulated RF signal. This signal is capacitively coupled from the shaft to a stationary antenna loop which surrounds the rotating collar. The signal is then carried via cable to the electronics unit where the RF signal is converted to an analog DC voltage representative of torque. Power for the transmitter is provided by the 160kHz induction power supply and coupled to the sensor via the stationary and rotating antennas.

3.3.2 Torque Signal Conversion

The RF signal is a duty cycle modulated 10 KHz pulse train driving a voltage controlled oscillator operating at 16.0 MHz. This RF signal is transmitted via the rotor and stator antennas to electronic circuitry on the torque receiver circuit assembly within the stationary electronics. The receiver circuitry demodulates the RF signal and recovers the 5 kHz duty cycle modulated signal. Shape, filter and amplifier circuits convert the 5 kHz signal into a DC output voltage linearly proportional to the torque input. An adjustable reference voltage is also an input to the circuit for adjustment of zero voltage output at zero torque input

3.3.3 RPM Detection

RPM information is obtained by measuring the time required for the shaft to make one half revolution. A magnetic pick-up mounted close to the collar generates a pulse each time a steel RPM trigger passes. The twice per revolution pulse is sent directly to the stationary electronic readout via a shielded cable for conversion to RPM data.

3.3.4 RPM Signal Conversion

At low RPM's the twice per revolution period signal is 25 millivolt peak to peak. It must be amplified and shaped before it can be used. General A/C 50/60 Hz line noise can easily swamp out the signal. Therefore, shielded, twisted cable is used to guard the signal. The period signal is amplified and shaped into a narrow pulse which is used to trigger the start and stop of pulses accumulated in the register. The number of pulses in the register is counted twice each revolution by a D to A converter. The RPM value is determined by calculating the reciprocal of the period. The shaped period pulse can also be used by the optional revolutions counter circuitry where it triggers the circuitry used to drive the revolutions counter.

SENSOTEC

3.4 Conditioning / Processing

3.4.1 Torque Output Voltage

The torque output voltage is scaled during system calibration to match predetermined engineering units. Circuit response capability of the torque receiver at this stage is DC to 100 Hz. A special filter circuit assembly is used to enable viewing of torque data on the front panel display. The circuit card has thumb wheel selectable time constants so that the amount of signal damping can be chosen. Scaling to engineering units is also performed on the filter assembly. The torque signal is routed to the HP/RPM calculator circuit for use in calculating instantaneous horsepower. It is also available at the record output terminals for use by remote panel readouts or other process equipment.

3.4.2 RPM Output Voltage

RPM output voltage is scaled to engineering units on the HP/RPM calculator circuit card and then routed to the front panel display. The RPM signal is also made available at the record output terminals for other use.

3.4.3 Horsepower Data

Horsepower data is calculated and scaled to engineering units on the HP/RPM PCB by using RPM and torque data. Horsepower data is routed to the front panel displays.

4.1 Introduction

This chapter provides incoming equipment inspection installation instructions for the Model 1202B Power Measurement System.

Special precautions regarding the handling of the 2120B transmitters are identified to preclude electronics failure. The user is advised to proceed through the bench-top familiarization prior to any attempt at installation. During the bench setup routines the operator will:

- Become familiar with the readout adjustments
- Learn the transmitter pin functions
- Learn how to resonate the PSU for optimal system performance

4.2 Equipment Inspection

4.2.1 Unpacking

Commercial standards are followed in packaging the 1202B Power Measurement System. Upon receipt, inspect the shipping cartons for evidence of damage.



CAUTION Do not remove the 2120B transmitter module from the 2126A collar assembly. Improper handling can cause internal component failure.

Check the unpackaged components against Table 1-2 on page 14 and the packing slip to ensure that all components are received.

4.2.2 Handling

Care must always be exercised in handling components to prevent loss of hardware, damage of components or injury to workmen.

Special care must be taken when handling, installing, or testing the transmitter. Always store the transmitter within the special wooden case in which it was delivered whenever it is not in use. The following caution applies to the 2120B transmitter module at all times.



CAUTION:

Before handling the transmitter module outside the 2126A collar, ground yourself by touching a grounded metal object such as electrical service conduit, a grounded metal work bench or machine. Do not pass the transmitter directly to a second person. Place the transmitter on an insulated surface from which the second person, who has been grounded as above, can retrieve it.

The Model 2126A clamp-on collar may be shipped with buss wire jumpers connecting the halves. If so do not disconnect them or loosen the bolts until after completion of the bench-top familiarization described later in this chapter.

4.3 System Familiarization

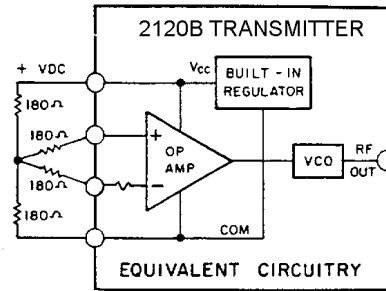

Figure 4-1: T-Circuit Bridge Simulation

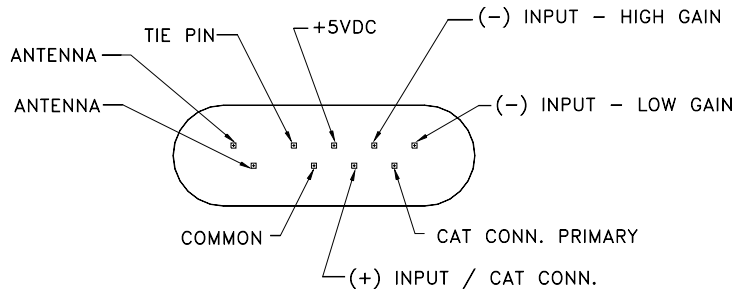

Figure 4-2: Model 2120B Transmitter Pin Functions

SENSOTEC

Pin Function	Comments
Antenna	RF Antenna Connection At Collar
Tie Pin	Not Used
+ 5VDC	Positive Supply
(-) Input - High Gain	Use with: 350 ohm bridge / 175 micor strain or 1000 ohm bridge / 500 micor strain
(-) Input - Low Gain	Use with: 350 ohm bridge / 1200 micro strain or 1000 ohm bridge / 1500 micro strain
CAT Conn., Primary	Calibrate Any Time Resistor Connection
(+) Input, CAT Conn. Secondary	Positive Input and CAT Resistor Connection
Common	+5 VDC excitation return and RF ground

Table 4-1: Model 2120B Transmitter Pin Functions

4.3.1 User Provided Torque Sensor

To simplify the familiarization procedure, four 180 ohm resistors and special socket connectors have been provided as accessories. These resistors will be configured into a "T" circuit which will satisfy all of the transmitter signal input impedance requirements at zero signal but will not have the critical balance problems. **Figure 4-1**;, "T-Circuit Bridge Simulation", **page 30** shows the equivalent circuit with the "T" connected to the 2120B transmitter. The "T" is also a valuable tool for trouble shooting as will be explained later.

4.3.2 Transmitter Module - Model 2120B

The Model 2120B transmitter is shown in **Figure 4-2**;, "Model 2120B Transmitter Pin Functions", **page 30** with wiring connections identified. **Table 4-1**;, "Model 2120B Transmitter Pin Functions", **page 30** further identifies each pin function. The transmitter is installed into the premachined cavity of the 2126A collar and secured with the screw and washer provided. To achieve full 15000 G operational use, the transmitter pins must be facing away from the center of rotation and parallel to the axis of rotation.

4.3.3 High Speed Collar - Model 2126A

Figure 4-3;, "Typical 2126A Collar Installation Assembly", **page 32** illustrates the general assembly arrangement of the rotating collar. There are four bolts assembled through the collar for strength and are not to be loosened. Bench setup instructions describe antenna/collar wiring connections. **Figure 4-4**;, "Operating RPM Limit vs. Shaft Size", **page 32** is a graph which shows the RPM operating limits of the collar versus the shaft diameter. Locate your shaft size and verify that the system will never exceed the RPM red-line.



WARNING:

Overspeed conditions can cause failure of the rotating assembly. A failure can cause damage to machinery and/or cause serious injury or death to personnel in the area.

DO NOT EXCEED THE RED-LINE RPM FOR LONGER THAN 30 SECONDS.

DO NOT EXCEED THE MAXIMUM RPM LIMIT, EVEN MOMENTARILY.

4.3.4 Power Separation Unit (PSU) - Model 1211D

The PSU is shown in **Figure 4-5**;, "Model 1211D PSU Installation Assy", **page 33** with the cover secure and a typical stationary antenna loop installed in the antenna mounting posts. The antenna is secured with two #10 socket head cap screws in each post. The antenna provided was used during system checkout at the factory and the PSU was set for resonance with it. Consult **Section 4.9**, "PSU Power Tuning", **page 47**, if your installation requires a change to the antenna configuration.

4.3.5 RPM Probe - Model 1213A

The Model 1213A Probe is illustrated in **Figure 4-6**;, "Model 1213A RPM Pickup Installation", **page 34**. This magnetic pickup detects the presence of passing magnetic material and is used to detect the RPM triggers mounted in the 2126A collar.

4.3.6 Readout Electronics - Model 1642A

The Model 1642A readout is illustrated in **Figure 4-7**;, "Model 1642A Electronics Readout", **page 35** with various components and controls identified. Function of the controls and displays will be explained later in this chapter.

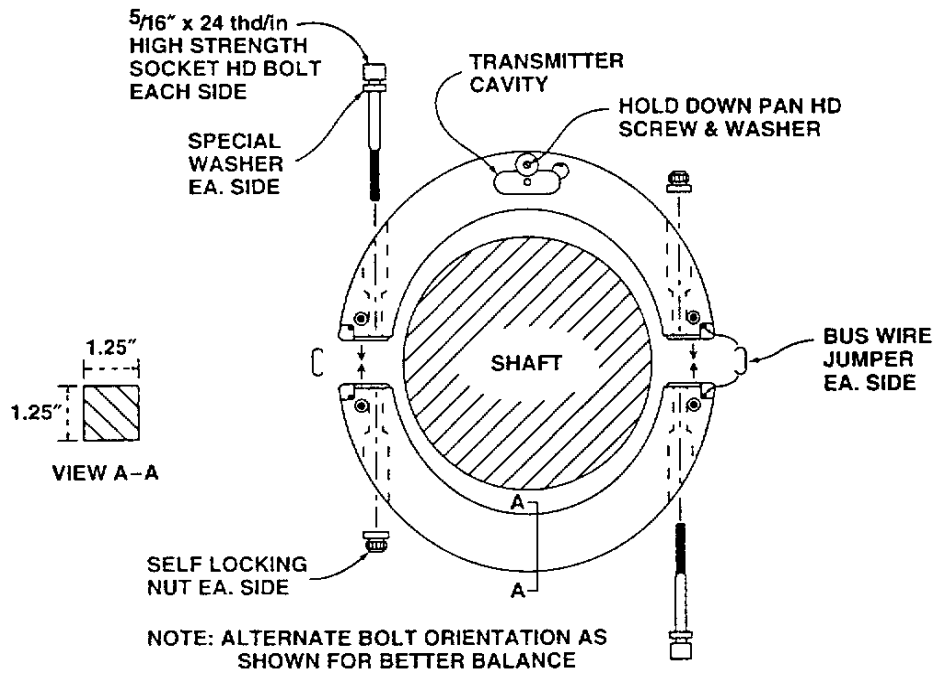

Figure 4-3: Typical 2126A Collar Installation Assembly

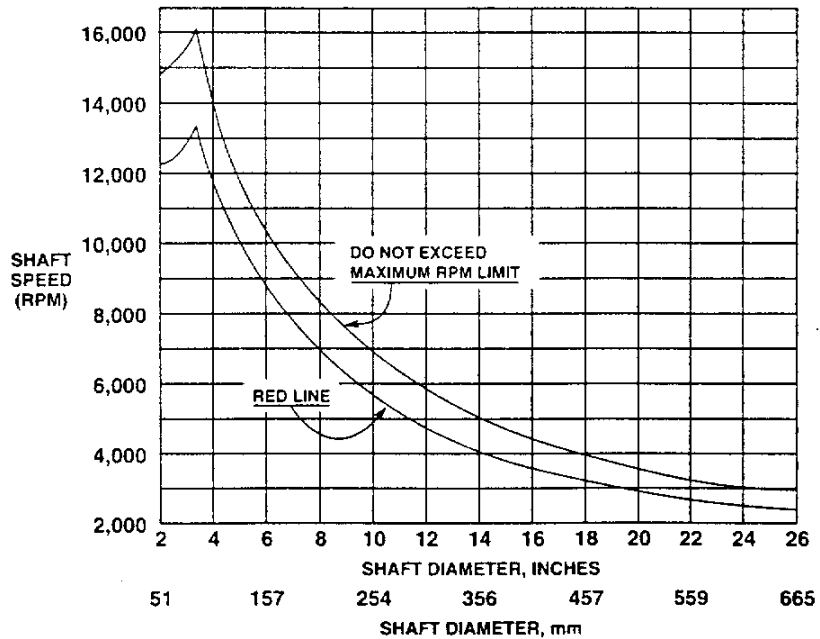

Figure 4-4: Operating RPM Limit vs. Shaft Size

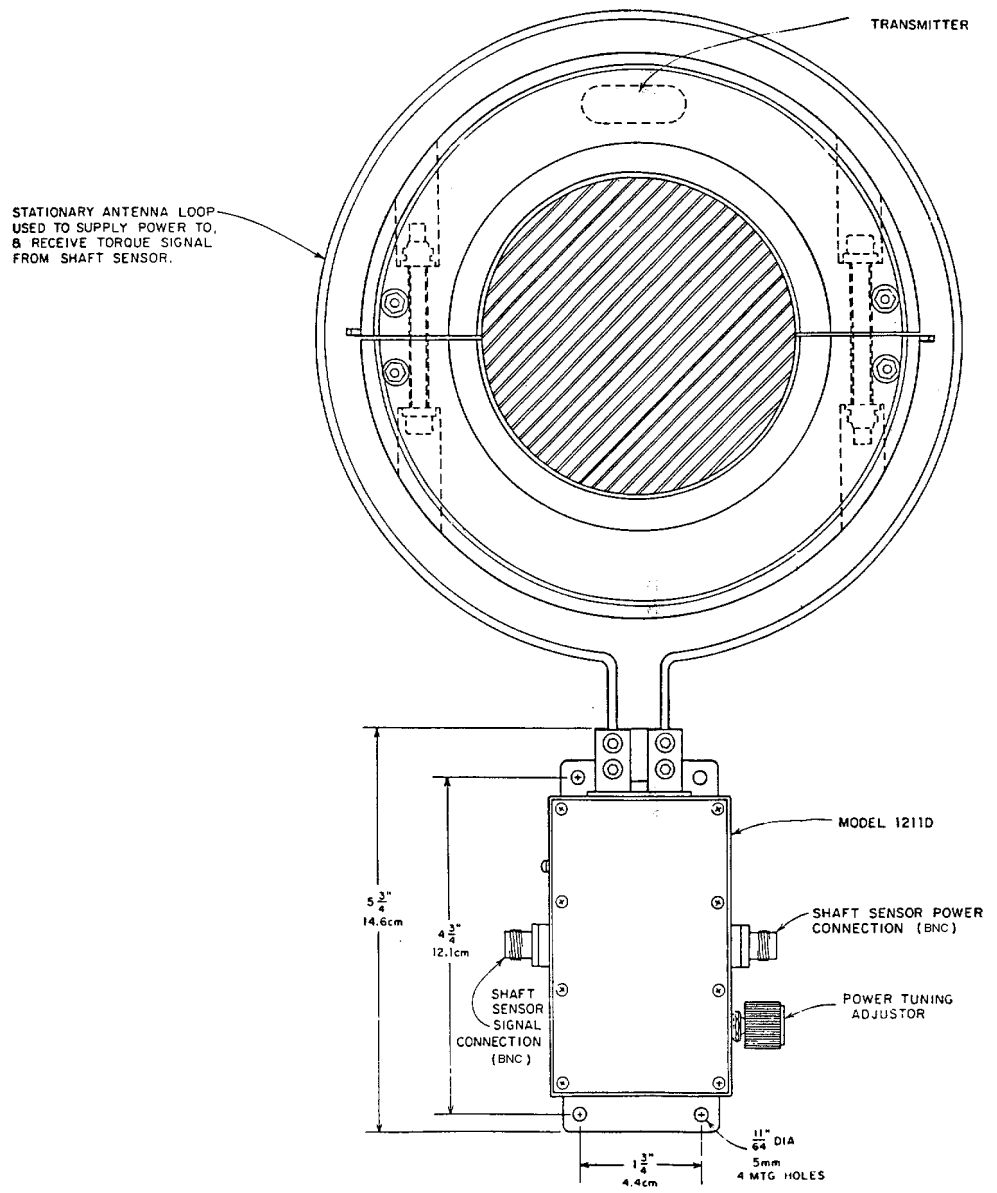

Figure 4-5: Model 1211D PSU Installation Assy

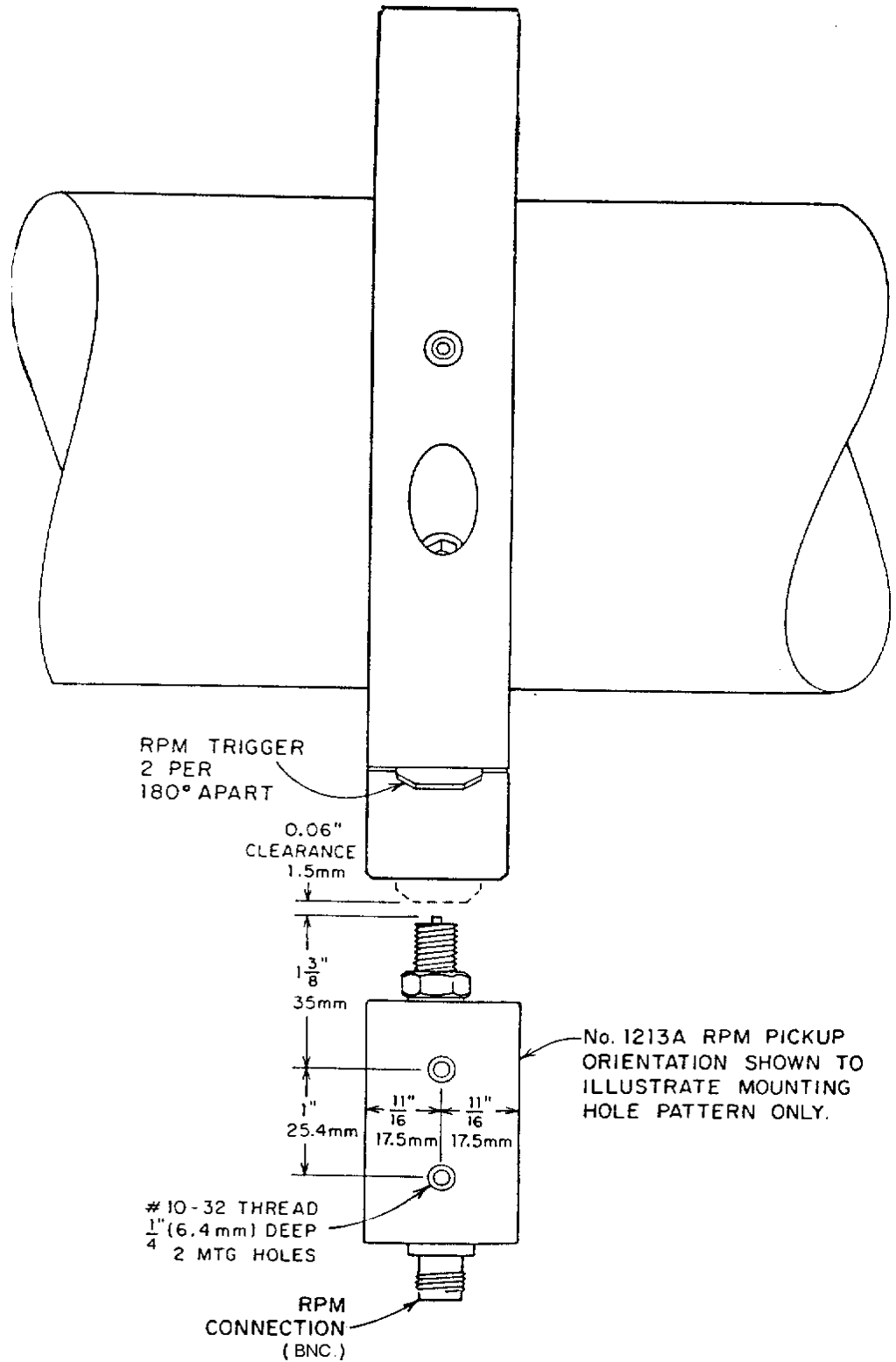

Figure 4-6: Model 1213A RPM Pickup Installation

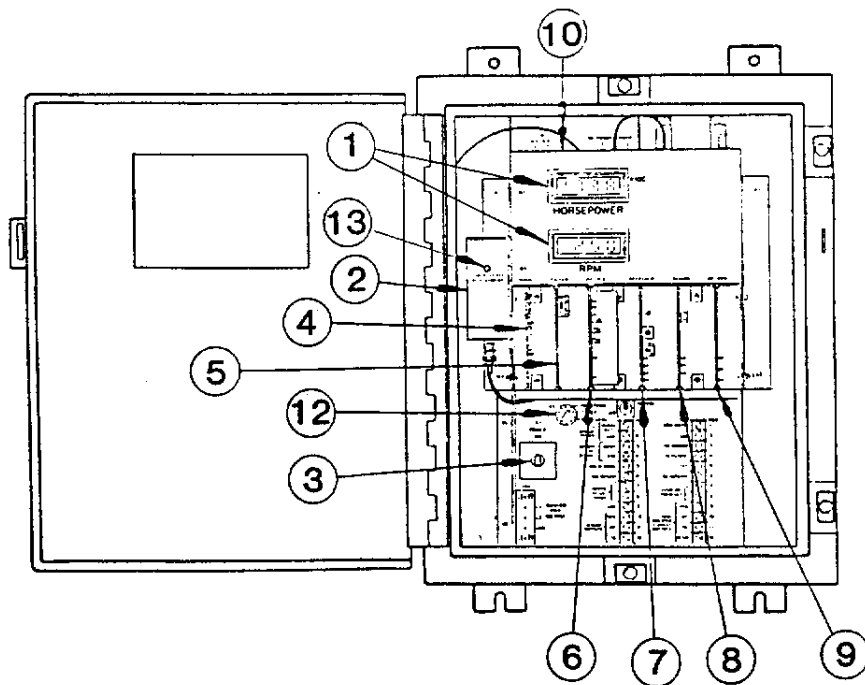
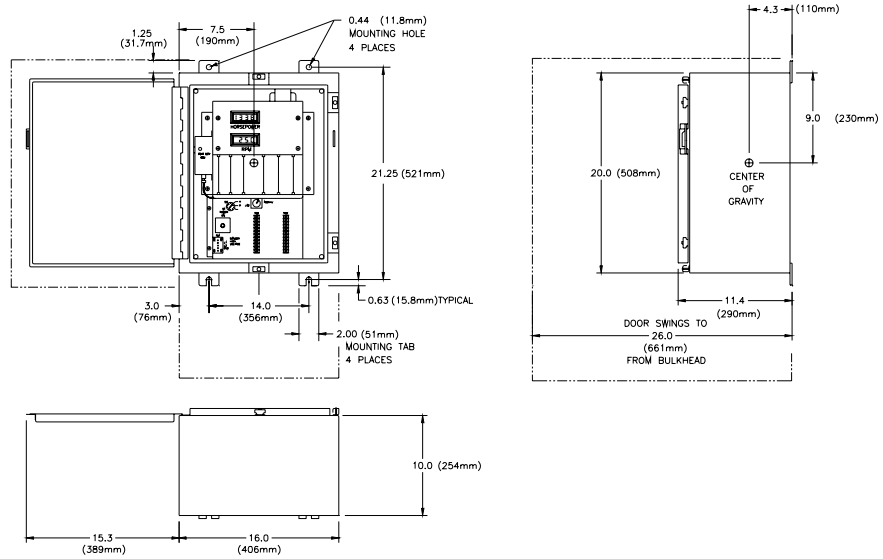

Figure 4-7: Model 1642A Electronics Readout

Item Number	Description
1	Digital Display
2	160 kHz Power Supply
3	Power ON-OFF Circuit Breaker
4	4 - 20 mA Isolated Output Adsssembly
5	20-Second Filter
6	15-Volt Power Supply
7	Receiver Assembly
8	Period Assembly
9	RPM/Horsepower Assembly
10	160 kHz Fuse, 2A, Behind Panel
11	Not Used
12	Selector Switch
13	60 kHz Power Control

Table 4-2: Model 1642A Electronics Readout Parts List

4.4 Operational Familiarization

The following bench check procedure is designed to walk the user through all of the steps necessary to obtain full function of the torque portion of the 1202B System. RPM probe alignment is specified in **Section 4.7, "Model 1213A RPM Probe", page 46**. RPM and power calculation with RPM and power display scaling is covered in **Chapter 5, "Calibration", page 51**.

4.4.1 Bench Checkout Criteria

The bench checkout requires that the following tools are available:

- Digital Voltmeter - 20 Volt range - 10 millivolt resolution.
- Ground-tip soldering iron - 25 watt nominal
- 60/40 Solder.
- 22 AWG Buss Wire Tinned.
- Wire cutters.
- Pointed nose pliers.
- Oscilloscope

The sockets provided with each system are to be used only during bench check. Sockets used on any circuit other than the "T" circuit may cause unstable readings because of poor electrical contact. In the following instruction, references to connections of transmitters pins, resistors and collar connections refer either to direct solder

connections or to the use of a socket.

Bench Check Setup

The bench check proceeds through the following steps:

- Collar assembly and wiring
- Transmitter insertion into the collar
- "T" circuit wiring
- PSU/Antenna loop assembly .
- System cabling and power up
- PSU tuning and power level adjustment
- Torque channel ZERO and GAIN adjustment

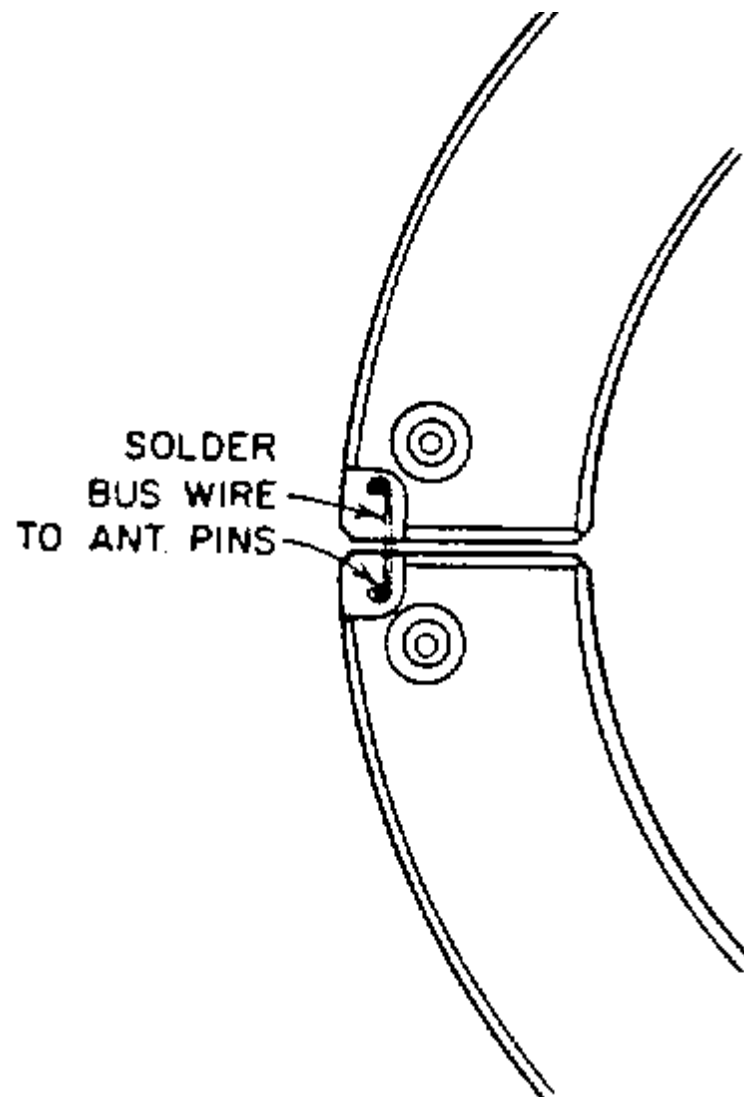

Figure 4-8: Rotating Antenna Wiring

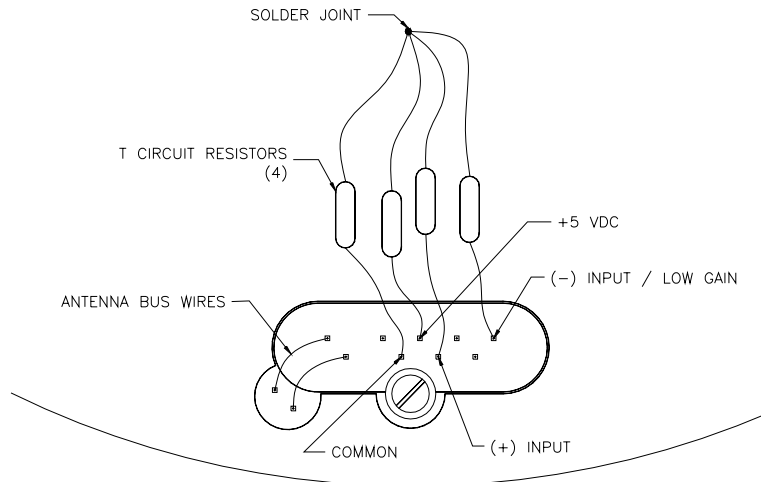

Figure 4-9: Transmitter Installation and T-Circuit Wiring

4.4.2 Collar Assembly

Lay the collar assembly on a bench with the transmitter's cavity up. Refer to **Figure 4-3**, "Typical 2126A Collar Installation Assembly", page 32 for correct assembly. Note that each half of the collar has recesses at the split with pins for antenna wiring completion. If not already assembled, loosely secure the halves with the bolts provided. If necessary also complete the antenna wiring as in **Figure 4-8**, "Rotating Antenna Wiring", page 37. These jumpers complete the rotating antenna loop the transmitter will use to pick up power. The loop is epoxied into a groove on the opposite side of the collar about 1/8 inch in and 1/8 inch deep from the corner.

4.4.3 Transmitter Wiring

Insert the transmitter into the collar with the pins away from the center of the collar. Refer to **Figure 4-2**, "Model 2120B Transmitter Pin Functions", page 30. Secure the transmitter with the screw and washer. Connect pins 1 and 2 of the transmitter to the collar pins as shown in **Figure 4-9**, "Transmitter Installation and T-Circuit Wiring", page 38. Prepare the "T" simulation circuit by soldering one end of the four 180 ohm resistors together. Carefully solder a socket to each of the resistors other end. Connect the "T" circuit as shown. The "T" circuit as connected will:

- Look like a 360 ohm load to the transmitter's regulator, just like a Wheatstone bridge.
- Appear to the transmitter's input circuitry as a balanced Wheatstone bridge, the circuitry will "see" the same impedance.
- Provide a zero input signal to the transmitter with the common model level exactly where the transmitter would like it to be.

4.4.4 PSU/Antenna Assembly

Insert the stationary antenna loop into the two mounting posts on the end of the PSU. During operation this antenna carries large currents. Therefore the ends of the loop must be clean and fully inserted into the posts. The two socket head cep screws in each post should be firmly secured for good electrical contact. Do not over tighten or threads could be damaged.

4.4.5 Cabling and Power-up

The 1202B System is provided with three cable assemblies. Each assembly has a BNC connector on one end with spade lugs on the other. There are two cables made up using RG-58 and one using RG-59 coax cable. Complete cabling between the readout unit and the RPM probe and PSU per **Figure 4-10**; "**Model 1202B Interconnect Cabling**", page 40. The red wire is the center conductor and the black wire is the shield on a cable assemblies. System power up begins by checking the settings of switches and controls on the Readout Unit. Refer to **Figure 4-11**; "**Model 1642A Electronics Readout Switches and Controls**", page 42.



CAUTION

Do not place the collar/transmitter assembly within the stationary antenna loop until instructed in the next paragraph. Damage to the transmitter electronics could result from a high induced power level.

- POWER SWITCH (S1) must be off
- LINE VOLTAGE on rear panel switch must match the local power outlet.
- SELECTOR SWITCH (S3) to "160 kHz level"
- Connect power cord to TB1, L1 and L2. TB1, L3 should be connected to the third wire safety ground.
- Apply power by switching power switch ON.

The displays should illuminate. The upper display outputs whatever is selected by S3. It now displays the peak to peak level of the 160 kHz Power Supply. Adjust the 160 kHz level, **Figure 4-11**; "**Model 1642A Electronics Readout Switches and Controls**", page 42, with a small flat bladed screw driver to read 005. This corresponds to 5 volts, 160 kHz peak to peak.

4.4.6 PSU Tuning and Power-Up

The induced power can now be set. Connect an oscilloscope to the collar antenna pins. (For best results use a X10 probe with <10pF and >10Mohm.) Slowly move the collar to the center of the stationary antenna loop. Note that the oscilloscope is measuring the 160KHz induced onto the rotating antenna and being applied to the transmitter. The waveform should be repetitive with a period of 6.25usec and may not be very sinusoidal. The peak to peak voltage should max-out as the collar assembly is passed through the stationary loop.

Raise the collar and find where the voltage is near maximum. Use some type of non-metallic spacer to hold the position of the collar for the next few steps. Without moving the PSU, rotate the switch on the side of the PSU through all positions. The voltage should peak somewhere near the mid-positions. The exact setting is not important. See **Figure 4-12**; "**Model 1211D PSU Internal View**", page 43. The fine-tuning and the gross capacitors are selected at the factory when doing a system test to achieve resonance of the stationary antenna at 160KHz. The peaking of the peak to peak voltage is indicative of resonance.

The 160KHz power level in the readout can now be increased to raise the regulated DC voltage of the transmitter to 5VDC. Once the regulated 5VDC is achieved on the transmitter, increase the 160KHz power level two or three turns on the potentiometer. This is the normal operating power level. Remove the spacer under the collar and slowly move the collar, note the point at which the regulated DC voltage drops by more than 0.03 volts. This is the limit of mechanical movement available before signal is lost.

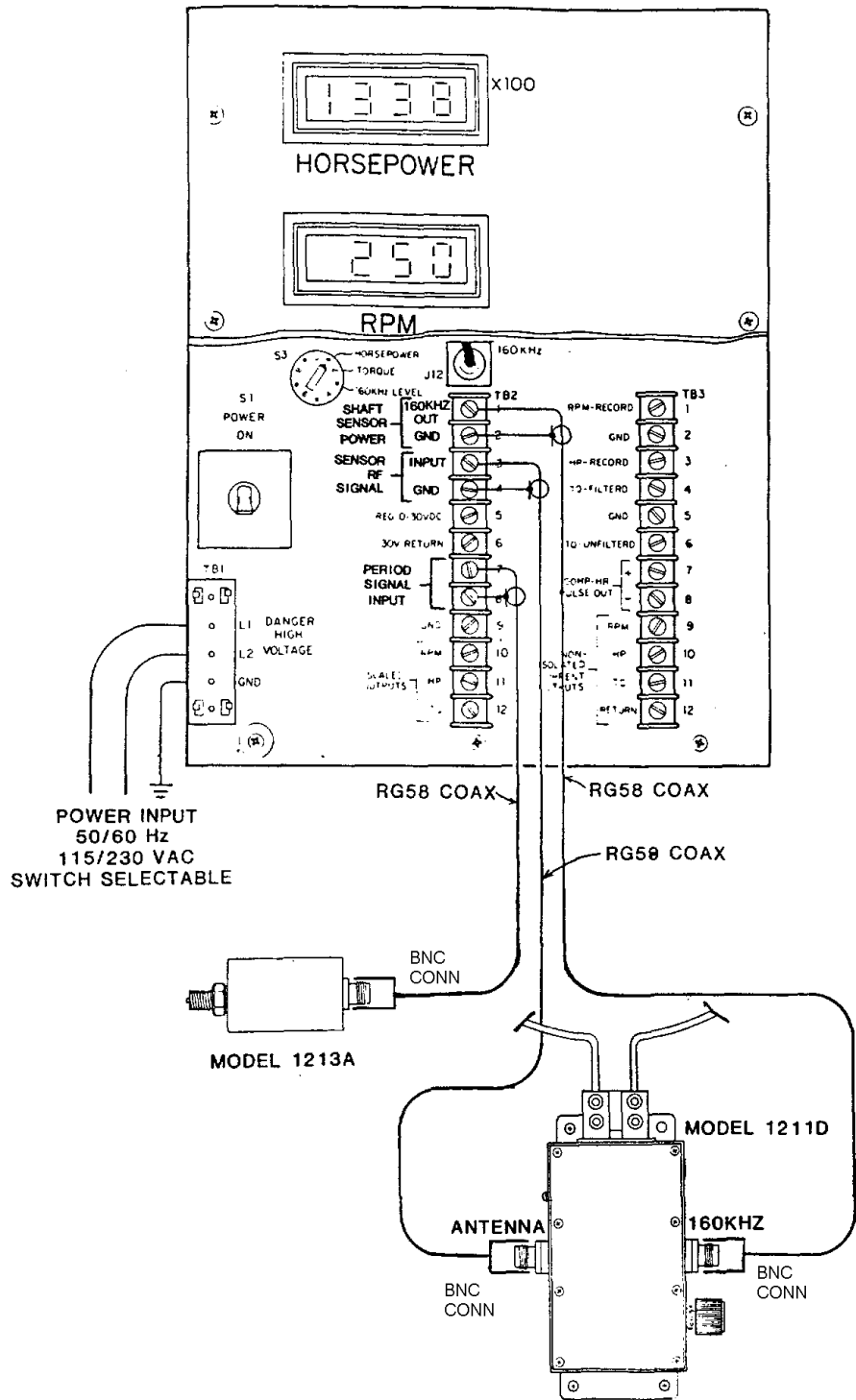

Figure 4-10: Model 1202B Interconnect Cabling

4.4.7 Torque Zero and Gain adjustment

Change the SELECTOR SWITCH (S3) to the "TORQUE" position. The upper display of the readout is now being used to view the output of the "T" circuit. Both switches on the receiver MUST be down.

The RF signal return path during normal operation is via the shaft/bearings ground. Since the bench check procedures do not involve a shaft set-up it will be necessary to add a temporary ground lead between the transmitter RF ground (Pin No. 6) and the case of the PSU. See **Figure 4-10**; "Model 1202B Interconnect Cabling", page 40. The displayed output of the "T" circuit zero will usually be unstable without this temporary lead.

Refer to **Figure 4-13**; "Receiver Zero and Gain Adjustment", page 44 which identifies the sensor zero adjust and fine gain adjust controls of the receiver. the fine gain adjust will only be active with a select resistor in the coarse gain adjust position.

Disconnect the voltmeter leads from the transmitter and reconnect them within the 1642A readout to TB3-6 (plus unfiltered torque signal) and TB3-5 (torque ground). The displays are limited to ± 1.999 volts and during the next steps the upper one may go blank due to overranging. All output references will be to the DVM connected to the record out terminals.

Adjust the SENSOR ZERO control as necessary to obtain zero volts after noting the range of adjustment. Simulate a torque signal by connecting a 39K ohm resistor between transmitter pins 6 and 8. The output should go positive a few volts if the two horizontal polarity jumpers JU1 and JU2 are connected and negative if the vertical polarity jumpers JU3 and JU4 are connected.

This completes the system familiarization. More detailed information on the Receiver gain adjust, calibration check and polarity reversal is included in the next section on calibration.

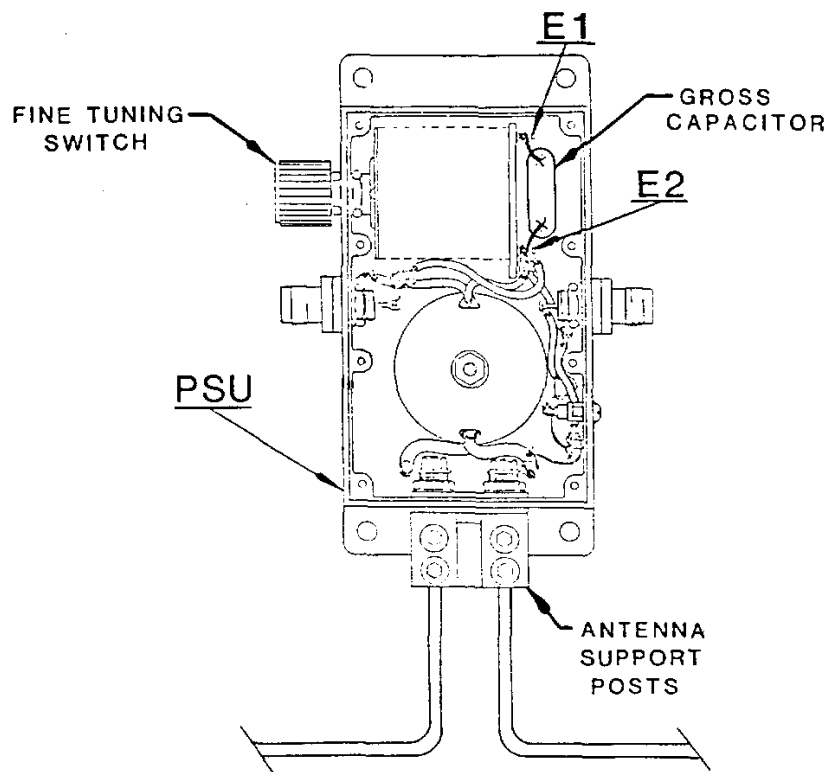

Figure 4-12: Model 1211D PSU Internal View

4.5 Installation

This section deals primarily with the mechanical considerations of installing the Model 2126A high speed collar, the Model 1213A RPM probe and orientation of the Model 1211D PSU/Antenna assembly. Information on power tuning of the PSU is also included for use when the system is used for a new application. This section does not contain information on installation of strain gages or any transducer.

4.6 Model 2126A High Speed Collar

Each collar assembly supplied has specific continuous running RPM limits of operation. Verify these limits of operation before proceeding by comparing the shaft diameter to the RPM limits shown in **Figure 4-4**; "Operating RPM Limit vs. Shaft Size", page 32



WARNING:

Overspeed conditions can cause failure of the rotating assembly. Failure can damage machinery and/or cause serious injury or death to personnel in the area

DO NOT EXCEED THE RED-LINE RPM FOR LONGER THAN 30 SECONDS.

DO NOT EXCEED THE MAXIMUM RPM LIMIT, EVEN MOMENTARILY.

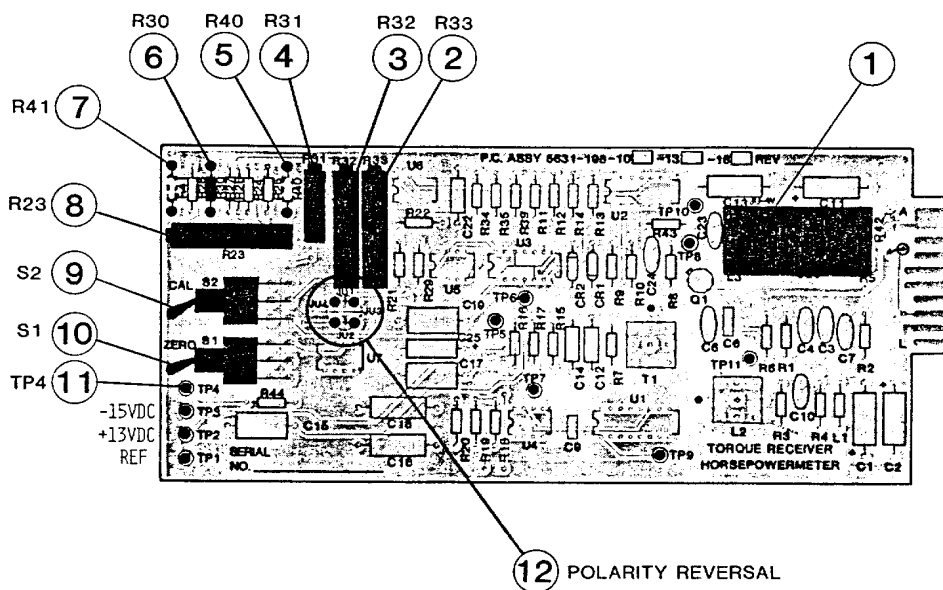

Figure 4-13: Receiver Zero and Gain Adjustment

Item	Designator	Description
1		BAND PASS FILTER 16.0 MHZ
2	R33	FINE GAIN ADJUST
3	R32	CAL ZERO ADJUST
4	R31	CAL SCALING FINE ADJUST
5	R4D	COARSE CAL REVERSE
6	R30	COARSE GAIN
7	R41	COARSE CAL NORMAL
8	R23	CHANNEL ZERO ADJUST
9	S2	CHANNEL CAL SWITCH - UP TO ACTIVATE WITH ZERO SWITCH UP ONLY
10	S1	CHANNEL ZERO SWITCH - UP TO ACTIVATE
11	TP4	5 KHZ MODULATED WAVE FORM
12		POLARITY REVERSAL JUMPERS JU1 AND JU2 - POSITIVE JU3 AND JU4 - NEGATIVE

Table 4-3: Receiver Zero and Gain Designators

After verification that the collar is safe to use in the application it is now time to assemble it on the intended shaft. The collar must be assembled as shown in Figure S-15 to assure the proper balance condition during high speed operation.

CAUTION: *Assembly of the collar must follow the arrangement of Figure 4-3:, "Typical 2126A Collar Installation Assembly", page 32 or vibration at speed could result.*

4.6.1 Collar Installation Tools

The following tools are required for the assembly of the collar on the shaft

- 1/4 inch Allen wrench
- 1/4 inch square drive torque wrench of at least 350 inch - pound range
- The 7/16 inch 12 point socket provided with 1202B System as an accessory

4.6.2 Collar Location

The collar was machined to match the user specified outer shaft diameter to within plus or minus 0.005 inch. The collar requires 1.25 inch of shaft length as it is 1.25 inches thick. However, wiring and power induction considerations dictate that at least 2 inches of clear shaft be left on both sides of the collar.



WARNING

Do not install the collar on a shaft with a diameter greater than or less than 0.010 inches from the specified outer diameter. The additional stresses produced due to bending will make the collar unsafe at high operating speeds.

4.6.3 Collar Assembly

Assemble the collar on the shaft using the bolts, washers and self locking nuts provided. Note that the washer fits under the head of the socket head, not under the nut. Torque the bolts alternately to 300 inch - pounds while checking the gaps between the halves for uniform spacing. Do not allow the gap on either side to close such that the halves touch.

4.6.4 Rotating Antenna Wiring

Carefully form two wire jumpers to complete the rotating antenna. Solder the connections at the locations as shown in **Figure 4-8:**, "**Rotating Antenna Wiring**", page 37. Locate the jumpers at the base of the pins to minimize stresses on the connections. Insert the Model 2120B transmitter into the cavity in the collar orienting it as shown in **Figure 4-9:**, "**Transmitter Installation and T-Circuit Wiring**", page 38 with the pin toward the outside of the collar. Secure the transmitter with the screw and flat washer. Form two buss wire jumpers to connect the transmitter to the antenna. Again locate the jumpers near the pin bases to minimize connection stresses. Attach the torque or strain gage bridge sensor leads to the transmitter using **Figure 4-14:**, "**Sensor Connection and Bridge Balance**", page 46 as a guide.

4.7 Model 1213A RPM Probe

The collar has two metal triggers installed during manufacture which are detected the RPM probe. It will be necessary to mount the probe assembly on a bracket which will allow adjustments so that the probe tip is oriented as shown in **Figure 4-6:**, "**Model 1213A RPM Pickup Installation**", page 34. The radial orientation of the probe about the shaft axis does not matter. The RPM probe will not sense shaft speeds below 5 RPM.

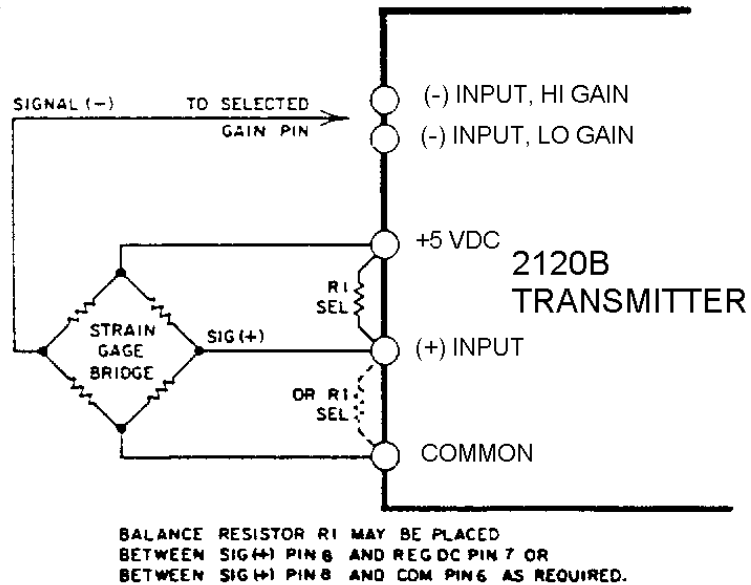

Figure 4-14: Sensor Connection and Bridge Balance

SENSOTEC

4.8 Model 1211D PSU / Antenna

The Model 1211D PSU, **Figure 4-5:**, "**Model 1211D PSU Installation Assy**", page 33, and stationary antenna transfer power to and receive RF signal from the transmitter / sensor on the rotating shaft. The proximity of the stationary antenna to the rotating antenna greatly effects the power level setting of the 160 KHz induction power supply. If the gap between the rotating and stationary antenna is doubled it will take about four times the induction power to assure proper operation. The stationary antenna loop which was shipped with the system is of a general size and was primarily used to check out the system prior to shipping. The PSU was tuned to match that antenna at system test. The system is designed to accept any antenna size but the PSU will require re-tuning.

4.8.1 Antenna Clearance

The typical gap between the rotating collar O.D. and the stationary collar I.D. is about 3/8 inch (9 mm). This gap will permit axial shaft movements of +/- 3/8 inch (+/- 9 mm). The rotating antenna is located about 1/8 inch under the O.D. of the collar and about 1/8 inch on the side opposite the transmitter cavity. In special circumstances where large metal covers or flanges are very close a concentric antenna can be located near the side of the collar. This configuration however will allow very little relative movement.

CAUTION Always monitor the transmitter unregulated DC power level carefully throughout a new antenna configuration setup. Failure to do so may cause circuit damage in the transmitter.

The closer the rotating antenna is to the stationary antenna, the greater the effect relative motion has on the unregulated D.C. magnitude.

4.8.2 PSU Mounting

The PSU/stationary antenna make up the RF receiving antenna and as such require a stable RF ground. The PSU should be mounted solidly using steel, aluminum or any good conductive unpainted bracket. Wires unless they are very, very short DO NOT provide a good RF ground. See **Figure 4-5**;, **"Model 1211D PSU Installation Assy"**, **page 33** for PSU mounting dimensions.

4.9 PSU Power Tuning

The Model 1211D PSU has been factory tuned for the stationary antenna loop supplied with the system. When ordering a separate unit, a spare, or when the application changes gross re-tuning may be necessary. Tuning involves selecting and installing a gross value of capacitance within the PSU assembly, see **Figure 4-12**;, **"Model 1211D PSU Internal View"**, **page 43**. Power tuning resonates the inductive reactance of the PSU transformer, the stationary antenna loop and any nearby metal. Tuning to resonance maximizes the power transfer across the gap for efficient operation.

4.9.1 Pre-Tuning Conditions

The PSU may require re-tuning after installation due to the presence of the shaft, a flange or bearing housings.

NOTE: When a maximum in the peak to peak voltage across the stationary antenna can be obtained within the adjustment range of the PSU fine tuning switch, power tuning is NOT required.

Verify the following in preparation for Power Tuning:

160KHz Power Level in the readout is 5 volts or less.

Antenna loop is securely mounted in the PSU support posts.

Coaxial cables are connected to PSU and readout per **Figure 4-10**;, **"Model 1202B Interconnect Cabling"**, **page 40**.

Readout Electronic is OFF.

Transmitter wiring is completed with the strain gage bridge connected.

Cover is removed from the PSU, see **Figure 4-12**;, **"Model 1211D PSU Internal View"**, **page 43**.

Gross Capacitor is removed from solder posts E1 and E2..

4.9.2 Equipment Required

- 25 Watt grounded tip soldering iron.
- Oscilloscope with X10 probes. (Alternately a DVM with a 1N914 diode and a 200pF capacitor.)
- DVM 20V range
- Capacitance Decade Box; zero to 0.05uF, with 500pF steps. (Alternately a variety of values 2400pF, 4700pF, 10,000pF, and 15,000pF 500 Volt mica capacitors.)

4.9.3 Power Tuning Procedure

Reference **Figure 4-12**:, "Model 1211D PSU Internal View", page 43;

a) Connect the Capacitance Decade Box across terminals E1 and E2. Set box at nominal value, i.e., 0.01uF.

If a Capacitance Decade Box is unavailable tuning can be achieved by substituting various values of fixed capacitors and using the FINE TUNING SWITCH to determine the resonance point. Remember avoid touching the capacitor terminals.

b) Set the PSU FINE TUNING SWITCH to position 5 or 6.

c) Connect the X10 probe to the stationary antenna terminal on the same side as the tuning switch, connect the X10 probe ground clip to the other stationary antenna terminal. Set Oscilloscope to 2V/div and 2usec/div.

If an oscilloscope is unavailable a DVM can be used with a 1N914 Diode (or similar) and a 200pF capacitor. Connect the banded end of the diode to one lead of the capacitor, then connect the other capacitor lead to one stationary antenna terminal and the non-banded end of the diode to the other stationary antenna. Connect the DVM to the banded end of the diode and the opposite end of the 200pF capacitor. The diode and capacitor will detect the peak voltage and the meter will display that value.

d) Turn ON the power to the readout unit. Adjust the 160KHz Power Level for 5V as measure on internal meter.



Caution: The voltage across the capacitor can reach several hundred volts, which may cause RF burns if touched.

e) Increase or decrease the decade box value while monitoring the peak to peak voltage across the stationary antenna. Adjust the value in the direction which causes an increase in the peak to peak level. At some point the peak to peak level will reach a maximum and begin to decrease. Note the capacitance value where the maximum occurs. The value of the capacitance noted is the optimum gross value needed to resonate the PSU with the FINE TUNING SWITCH in position 5 or 6.

f) Turn OFF power to the readout unit. Disconnect the decade box. Install a MICA capacitor (500 working volts) between E1 and E2 equal to or as close as possible to the value noted in step e). Each step on the FINE TUNING SWITCH is 470pF.

Note: Selecting a value within a plus or minus 1000pF tolerance will assure peaking within the FINE TUNING SWITCH range.

g) Turn ON the power to the readout unit. Verify the correct capacitance is installed by using the FINE TUNING SWITCH to maximize the peak to peak voltage. If the maximum occurs at either end of the FINE TUNING SWITCH adjustment range the value of the gross capacitance will need to be adjusted. Leave the switch at the position where the voltage peaks.

h) Measure the regulated voltage on the 2120B transmitter. Adjust the 160KHz Power Level until the 5V regulation is achieved. Once the regulated 5VDC is achieved on the transmitter, increase the 160KHz Power Level two or three turns on the potentiometer. This is the normal operating power level.

i) Disconnect all test leads and reinstall the PSU cover.

5.1 Introduction

This chapter provides information on how to:

- Setup operational RPM ranges
- Select scaling resistors for direct viewing of RPM, power and torque.
- Zero and gain adjustments for transmitter and the receiver.
- Calibration of torque input.

The computational plug-in cards in the readout have been factory calibrated to compute power over specific input ranges of torque and RPM.

5.2 Power Definitions And Formulas

Brake Horsepower (Bhp) - is the horsepower delivered by the shaft of an engine at the output end.

lhp (British) = 550 pound feet per second

$lhp \text{ (British)} = T_p \times N / 5252.113$

Where: T_p = Torque, lb-ft.

N = Shaft speed, RPM

$lhp \text{ (British)} = T_n \times N / 7120.92$

Where: T_n = Torque, N-m

1 metric HP = 735.499 Watts

1 metric HP = 0.9863 x lhp (British)

1 N-m = 0.737562 lb-ft

5.3 Calibration - Overview

System calibration of the Model 1202B will be discussed as follows:

- Review of the potential task to determine what power and RPM range should be set on the 1202B readout to best cover the application.
- Install RPM range jumpers on the universal RPM board and set the calibration adjust.
- Select and install HP and RPM scaling resistors on the calculator board.
- Select and install a torque scaling resistor on the filter board.
- Set the gain on the torque receiver card.
- Set the calibration check circuit on the receiver card.

5.4 Application Review

- Main pump power: 20,826 Bhp
- Main shaft speed: 6000 RPM max.
- Shaft OD: 6.44 inch
- Torque to be monitored: 18,230 lb-ft.
- Modulus of Rigidity = 11.87×10^6 PSI

5.5 Universal RPM - Range Select P/N 5631-230

The universal RPM plug-in board is designed to be range changed by soldering jumpers in positions SW1 and SW2. See **Figure 5-1**; "Universal RPM PCB", page 53. Jumper positions are determined by the number of RPM triggers in the system and the RPM range of the system.

If two RPM triggers are used $N = 360,000$ divided by the desired RPM range. If one RPM trigger is used $N = 720,000$ divided by the desired RPM range.

EXAMPLE - One trigger operating at 6000 RPM:

- $N = 720,000/6000 = 120$ (always round to nearest whole number)
- Place jumpers at 64, 32, 16, 8
- All other jumper locations **MUST** be open.

EXAMPLE - Two triggers operating at 6000 RPM:

- $N = 360,000/6000 = 60$ (always round to nearest whole number)
- Place jumpers at 32, 16, 8, 4
- All other jumper locations **MUST** be open.

Plug the Universal RPM board into the extender and insert the extender into the Period slot. Allow 15 minutes for warm up. Push SW3 Cal Check and measure $+1.000 \pm 0.001$ VDC at TP16 with common at TP17. Adjust potentiometer R15 as necessary to set to the required voltage.

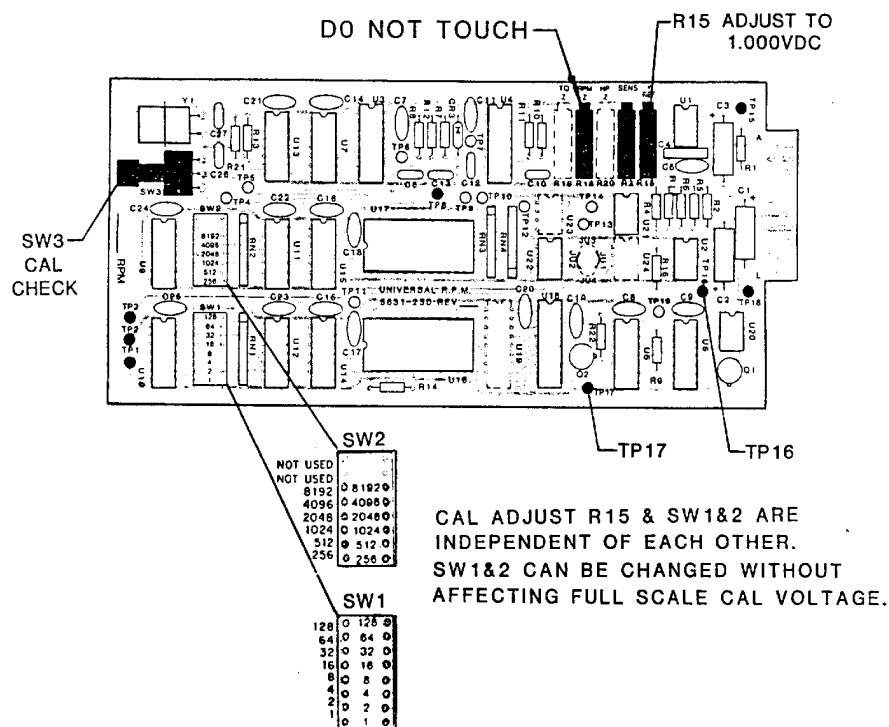

Figure 5-1: Universal RPM PCB

5.6 Install Display Scaling Resistors

The RPM, HP and torque engineering unit displays obtain their input from voltage dividers located on the RPM & HP calculator and the filter card. The voltage dividers utilize the record output voltage of each parameter as a source voltage. Full scale RPM and HP record voltage are each 10.00 volts. Trim pots in each circuit allow for $\pm 3\%$ at low (100ohm) resistance to $\pm 9\%$ at higher resistance values (3500ohm). Use the following equation to calculate the ideal scaling resistor and then apply the trim tolerance to select a specific resistor. All scaling resistors should have a temperature coefficient of 50 PPM or better. Displays cannot show numbers greater than 1999.

$$I_r = 10000 * D_v / (10000 - D_v)$$

I_r = Ideal Resistor (ohms) with 10.0 Volts across divider.

D_v = Desired Display Value (millivolts)

The scaling circuits on the RPM and HP calculator card and the filter card will allow for the +10.00 VDC Voltage source to be placed on test terminals without damage to the circuits or components. However, the boards must be removed from the readout and placed on a insulated surface first. The board will not be damaged if it is powered up upon application of the 10.0 VDC power supply but major scaling errors will result.

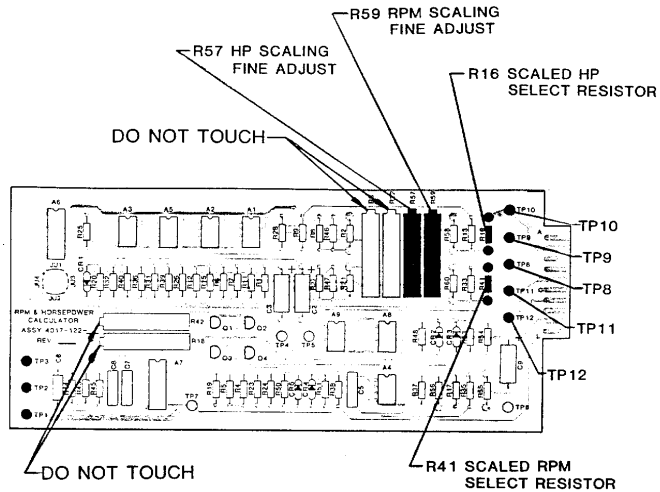

Figure 5-2: HP / RPM Calculator PCB

5.6.1 RPM & HP Calculator - P/N 4017-122

Compute values of select resistors for RPM and HP scaling.

Example:

RPM:

$$10000 \times 6000 / (10000 - 6000) = 15K \text{ ohms ideal } \pm 3\% \text{ Tol.}$$

Use a resistor between 15.4K ohms and 14.6K ohms.

Closest 1% RN55C type resistor is 15K ohms.

HP:

$$10000 \times 30000 / (10000 - 30000) = 15K \text{ ohms ideal } \pm 3\% \text{ Tol.}$$

Use a resistor between 15.4K ohms and 14.6K ohms.

Closest 1% RN55C type resistor is 15K ohms.

Refer to **Figure 5-2**, "HP / RPM Calculator PCB", **page 54** for the location on the plug-in board to solder select resistors. Position R41 is used for the RPM scaling resistor and R16 for the HP scaling resistor.

Allow about 20 minutes for the solder connections and resistors to cool before continuing with next step. Connect a +10.00 VDC source to TP11 with the common connected to TP10. Connect a voltmeter to TP12 with the reference at TP10. Adjust R59 to exact scaled RPM value in millivolts. Move the +10.00 VDC source to TP8 with common remaining on TP10. Move the voltmeter plus input to TP9 with common remaining on TP10. Adjust R57 to exact scaled HP value in millivolts. Final trim on both scaling outputs can be checked in the readout after completing calibration of torque input.

5.6.2 Torque Filter P/N 5631-062

The torque record output is +5.000 VDC rather than 10 volts so computation of the select resistor for torque requires working with 2 times the desired display number.

EXAMPLE:

Torque:

The torque display should read 262 (x1000) lb-ft at full scale, i.e., 5.00 volts out. It is necessary to double the desired number (260 x 2 = 520) and then perform the calculation.

$$10000 \times 520 / (10000 - 520) = 549 \text{ ohms } \pm 3\%$$

Use a resistor between 565 ohms and 532 ohms.

Closest 1% RN55C value is 549 ohms.

Refer to **Figure 5-3**, "Filter PCB", page 55 for the location on the plug-in board to solder the select resistor. Solder select resistor at R32. Allow about 20 minutes to cool. Connect a +5.00 VDC source to TP10 with common to TP11. Connect a voltmeter to TP9 with common to TP11. Adjust R34 to exact scaled torque value in millivolts.

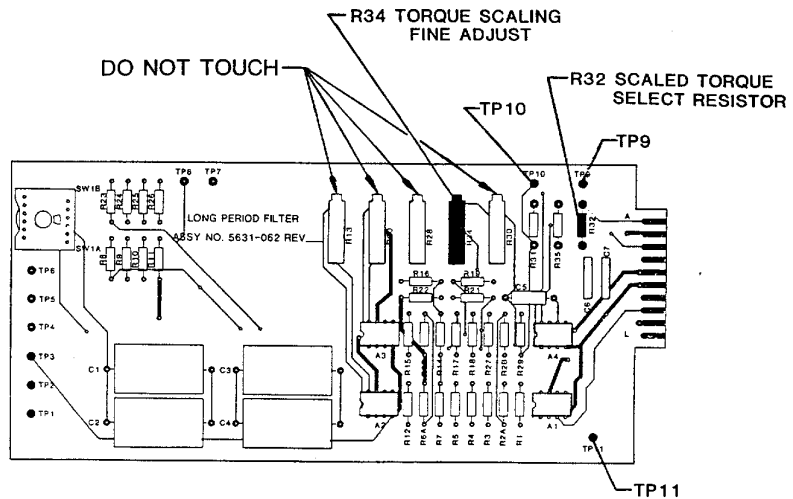

Figure 5-3: Filter PCB

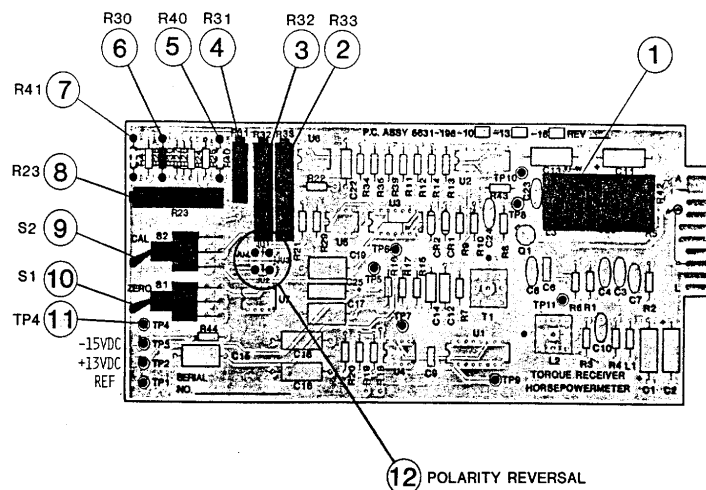

Figure 5-4: Receiver PCB

5.7 Torque Calibration Overview

The torque measurement components of the 1202B System consist of the 2120B transmitter and the plug-in receiver, P/N 5631-198, installed in the 1642A readout. The 2120B transmitter interfaces to the Wheatstone bridge sensor being used to monitor torque via the strain in the shaft under load. The receiver conditions the transmitter signal and provides convenient final zero and gain adjustments for calibration. There are two methods of adjusting both the torque signal zero and gain. Gross adjustments should be made at the transmitter with fine adjustments at the receiver. Normally it is best to operate the system in a manner that produces maximum ideal gain in the transmitter. This will yield maximum resolution and minimum system noise. The ideal transmitter gain and receiver gain will result in the correct full scale reading, i.e., 5.00 volts.

5.7.1 Setting Transmitter Gain

An ideal transmitter gain is achieved when the duty cycle modulated signal as seen with an oscilloscope at TP4 of the receiver changes from 50/50 to 30/70 or 70/30. Connect the "T" circuit as instructed in 4.4, "Operational Familiarization", page 36, and obtain the 50/50 duty cycle. This condition is the normal zero of the transmitter and any change in duty cycle is the signal the receiver amplifies as a valid torque signal. The modulation range does not have to be precise for the system to function properly. The examples 1 and 2 will identify tolerances of +10% and -20% of the modulation which allows the user latitude in setting up the system. Modulation from 50/50 (zero) to 31/69 or 28/72 (full scale) can easily be handled by the receiver gain adjust. The gain of the transmitter is controlled by the input impedance at the negative input connection. **Figure 5-5: "Sensor Bridge / 2120B Transmitter Interface", page 57** shows a model of a strain gage bridge connected to an equivalent circuit of the 2120B transmitter. The input impedance to the transmitter and an internal feedback resistor establish the transmitter gain. The transmitter has a high gain pin and a low gain pin. However by using the tie pin and a series resistor any strain level greater than 175 microstrain can be accommodated. See **Figure 5-6: "Resistance vs. Microstrain Input to 2120B Transmitter", page 58** for approximate series resistance for strain inputs up to 5000 microinches per inch.

EXAMPLE 1:

A 350 ohm bridge is connected to the transmitter. High gain is used as the negative input. One half of the bridge impedance in terms of microstrain, or 175 micro inch per inch will then be considered full scale transmitter input.

EXAMPLE 2

:A 1000 ohm bridge is connected to the transmitter. Low gain is used as the negative input. One half the bridge impedance, plus the internal 1000 ohms in terms of microstrain is full scale. I.e., 1500 micro inches per inch.

5.7.2 Other Bridges, Other Strain Levels

For those cases where the bridge resistance and strain level does not fit in the range of **Figure 5-6**: "**Resistance vs. Microstrain Input to 2120B Transmitter**", page 58, use the following formula to calculate an external series resistance.

$$R_s = (KE - R_g) / 2$$

Where: K = Gage Factor

E = Strain level in micro inches per inch

R_g = Wheatstone bridge gage resistance

EXAMPLE 1:

A 500 ohm bridge with a gage factor of 2.07. Expected strain level will be 3750 microstrain.

Solution - R_s = 7262 ohms +10% - 20%

Install a series resistor, 100 PPM or better; value between 5800 ohms and 8000 ohms between pins 9 and 11. Connect the negative signal input to pin 11.

EXAMPLE 2:

A 1000 ohm bridge with a gage factor of 1.96. Expected strain level of 4,500 microstrain.

Solution - R_s = 3910 ohms +10% - 20%

Install a series resistor, 100 PPM or better; value between 3100 ohms and 4300 ohms between pin 9 and 11. Connect the negative signal input to pin 11.

EXAMPLE 3:

A 350 ohm bridge with a gage factor of 2.02. Expected strain level of 135 microstrain. No calculation necessary. Connect negative input to Pin 9. Additional gain adjust will be taken care of on the receiver card.

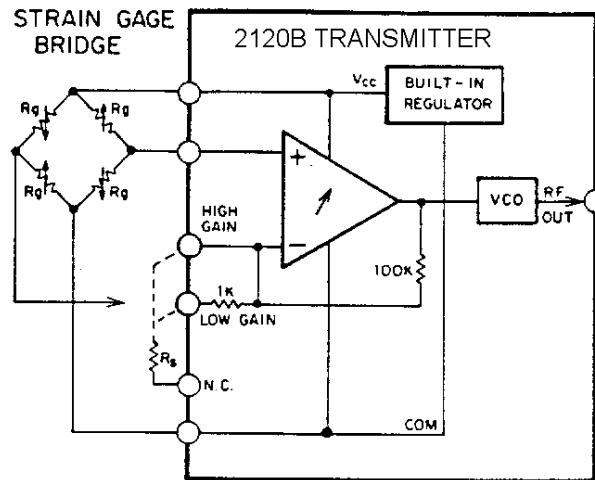

Figure 5-5: Sensor Bridge / 2120B Transmitter Interface

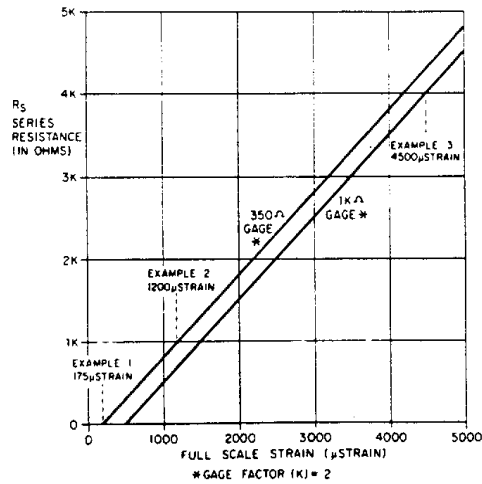

Figure 5-6: Resistance vs. Microstrain Input to 2120B Transmitter

NOTE: Strain levels below 50 microstrain on a 350 ohm bridge and below 150 on a 1000 ohm bridge may show some thermal instability due to the extremely high system gain if the output voltage is raised to 5.00 Volts Full Scale.

5.8 Setting Transmitter Zero By Balancing The Bridge

Transmitter zero, 50/50 duty cycle at zero torque input is necessary for the receiver zero adjust circuit to provide its full range of setting. The receiver zero control has a wide range of adjustment, +/-50%, which eases the setting of zero on the transmitter. However, care must still be exercised when balancing the bridge. Shunt or series balancing of the bridge to 50/50 duty cycle using high stability fixed resistors is the only recommendation. Potentiometers are very susceptible to vibration and most have very high, >500 PPM thermal coefficients. Should there be a necessity to use a potentiometer to balance the strain gage and the system exhibits an unstable signal check for source of instability using the "T" circuit as discussed in Chapter 4.

5.9 Setting Torque Receiver Gain And Calibration Check

The torque receiver plug-in card has solder terminals at R30 for locating a coarse gain resistor. The fine gain adjust located at R33 is a 10 Turn 200 ohm potentiometer. The fine gain is ineffective without a select resistor installed at R30. Setting the torque channel output level to 5.00 Volts will require the following equipment:

- a) DVM - 10 Volt Range - readable to nearest 0.001 volt.
- b) Resistance Decade Box - less than 10K ohms

5.9.1 Receiver Calibration

The following calibration sequence assumes that total system has been installed properly with the strain bridge wired to the transmitter and zero balanced to allow nor-

mal operation of the receiver zero control. The 160 kHz power level is nominal and an arbitrary signal input by shunt resistor or shaft loading causes a receiver output change. The equipment has also been powered up long enough to assure stable system operation. The receiver plug-in board is on the extender.

5.9.2 Calibration Sequence

- a) Connect the DVM to TB3-6(+) and TB3-5(-) within the Receiver.
- b) Connect the resistance decade box to the R30 terminals of plug-in receiver 5631-198.
- c) Adjust the Fine Gain R33 pot to approximately mid-point.
- d) Induce Full Scale strain to the torque transducer by either shunt calibration or known load application.
- e) Adjust the decade box to achieve 5.000 volts output. If polarity of output is wrong for application reverse connections at pins 6 and 7 of the transmitter.
- f) Remove full scale strain input.
- g) Select a stable resistor, 50 PPM or better, to match the decade box value within plus or minus 75 ohms. Solder the resistor between terminals at R30 and allow at least 30 minutes cooling time before making any adjustments or proceeding with the next step.
- h) Activate Switch S1 to the UP position.
- i) Adjust R32 to eliminate the output amplifier offset. Reduce the offset to less than one millivolt.
- j) Return S1 to the DOWN position.
- k) Adjust R23, Zero Adjust, until the DVM shows less than one millivolt.
- l) Apply Full Scale input and adjust R33 until the DVM shows 5.00 Volts within one millivolt.
- m) Repeat steps k) and l) as necessary.

5.10 Setting Torque Calibration Check (Optional)

The torque calibration check is an artificial means of generating a signal which along with the RPM calibration check push button on the RPM card allows full scale verification of all record outputs and display values. The calibration check function utilizes the receiver amplifier gain stage after it has been calibrated for the specific application. As such the calibration check can be used to verify the original gain setting. Setting the calibration circuit requires use of only the 1642A Readout. The unit should be powered-up long enough to assure stable circuits and the receiver plug-in should be inserted into the extender which is in the receiver slot. Connect the DVP7 to TB3-6(+) and TB3-5(-). Connect the decade resistance box across R40 or R41 terminals. The only difference between the locations will be the polarity of the calibrate signal. Choose the location which produces the correct polarity cal check signal for the application.

- a) Activate Switch S1 to the UP position.
- b) The DVM should indicate zero plus or minus one millivolt.
- c) Activate Switch S2 to the UP position and adjust the Decade box until 5.00 volts is indicated on the DVM. R31 should be in mid-position at this time.
- d) Select a stable resistor, 100 PPM TEMPCO or better, within plus or minus 9000 ohms of the selected value.

- e) Remove the receiver plug-in and solder the resistor into R40 or R41 position as chosen for correct polarity. Allow 30 minutes cooling time before proceeding with next step.
- f) Readjust R31 to achieve 5.00 volts plus or minus one millivolt on the DVM.
- g) Return both S2 and S1 to the DOWN position. Perform all steps **Section 2.4.2, "Calibration Check Mode"**, page 18 to verify correct setting of all record outputs and displays.

5.11 Polarity Reversal Of Torque Record Output

The receiver output polarity can be reversed without affecting torque calibration by changing the location of two solder-in jumper wires. **Section Figure 4-13; "Receiver Zero and Gain Adjustment"**, page 44 identifies the polarity reversal jumper location when either JU1 and JU2 or JU3 and JU4 are installed. Reverse the output polarity by simply desoldering the wire jumper set and resoldering in the opposite locations.

NOTE: If the Cal Check polarity must also be reversed desolder from R40 or R41 location and resolder in opposite location. Adjustment of R31 for 5 Volts output will be required. In rare cases the Coarse Cal resistor may have to be changed to a new value.

Warranty/Repair Policy



Limitation of Remedy and Disclaimer of Warranty

Any of our products which, under normal operating conditions, proves defective in material or in workmanship within one year from the date of shipment by Sensotec, Inc., will be repaired or replaced free of charge, provided that the buyer (1) promptly notifies Sensotec, Inc. of any such defect; (2) provides Sensotec, Inc. with satisfactory proof of the defect and that the product was properly installed, maintained, and operated within the limits of rated and normal usage; and (3) obtains from Sensotec, Inc. authorization to return the product. Any such product shall be returned with transportation charges prepaid. The replacement product will be shipped F.O.B. our plant.

The remedy set forth herein does not extend to any product or part thereof which, under normal usage, has an inherently shorter useful life than one year. The remedy set forth herein does not apply to damage or to defects in any product caused by the buyer's misuse or neglect, nor does it apply to any product which has been repaired or disassembled which, in the sole judgement of Sensotec, Inc. affects the performance of the product.

The remedy set forth herein is the buyer's exclusive remedy, and will satisfy all obligations of Sensotec, Inc. whether based on contract, negligence, or otherwise. Sensotec, Inc. is not responsible for any incidental or consequential loss or damage which might result from a failure of any Sensotec, Inc. product.

THIS EXPRESS WARRANTY IS MADE IN LIEU OF ANY AND ALL OTHER WARRANTIES, EXPRESSED OR IMPLIED, INCLUDING IMPLIED WARRANTY OF MERCHANTABILITY OR FITNESS FOR PARTICULAR PURPOSE.

Obtaining Service Under Warranty

Advanced authorization is required prior to the return to Sensotec, Inc. Before returning the items, either write to the Repair Department c/o Sensotec, Inc., 2080 Arlingate Lane, Columbus, Ohio 43228, or call (800) 848-6564 with: 1) a part number; 2) a serial number of the defective product; 3) a technical description* of the defect; 4) a no-charge purchase order number (so products can be returned to you correctly); and 5) ship and bill addresses. Shipment to Sensotec, Inc. shall be at Buyer's expense and repaired or replacement items will be shipped F.O.B. our plant in Columbus, Ohio. Non-verified problems or defects may be subject to an evaluation charge. Please return the original calibration data with the unit.

Obtaining Non-warranty Service

Advance authorization is required prior to the return to Sensotec, Inc. Before returning the item, either write to the Repair Department c/o Sensotec, Inc., 2080 Arlingate Lane, Columbus, Ohio 43228, or call (800) 848-6564 with: 1) a part number; 2) a serial number of the defective product; 3) a technical description* of the malfunction; 4) a purchase order number to cover Sensotec, Inc.'s repair cost; and 5) ship and bill addresses. After the product is evaluated by Sensotec, Inc., we will contact you to provide the estimated repair costs before proceeding. The minimum evaluation charge is \$95. Shipment to Sensotec, Inc. shall be at Buyer's expense and repaired items will be shipped to you F.O.B., our plant in Columbus, Ohio. Please return the original calibration data with the unit.

Repair Warranty

All repairs of Sensotec, Inc. products are warranted for a period of 90 days from date of shipment. This warranty applies only to those items which were found defective and repaired. It does not apply to products in which no defect was found and returned as is or merely re-calibrated. Out of warranty products may not be capable of being returned to the exact original specifications or dimensions.

*Technical description of the defect: In order to properly repair a product, it is necessary for Sensotec, Inc. to receive information specifying the reason the product is being returned. Specific test data, written observations on the failure and specific corrective action you require is needed.



Product of Sensotec Inc.

(800)848-6564

2080 Arlingate Lane
Columbus, Ohio 43228

Tel: (614)850-5000

Fax: (614)850-1111

E-mail: service@sensotec.com

<http://www.sensotec.com>